



# Connector & Electrical Technical Guidelines



Enhancing Interoperability of 12V Solar Home Systems and Appliances

Version 1, August 2022



Image: Fenix International

## Acknowledgements

Our thanks and recognition to the Efficiency for Access Coalition which provided financial support from UKaid for the creation of this document.

The document has been written by Chris Moller (Evonet) with guidance from Drew Corbyn (GOGLA) in consultation with:

GOGLA's Technology Working Group:

Angaza (Chad Norvell)  
Azuri Technologies (Nigel Preston, Duncan Barclay)  
Biolite Energy (Ryan Gist)  
BBOX (Phillip Homer, Fabian Iriarte)  
Fosera (Daniel Goldbach)  
Global Ice-tec (M. Schohe)  
Opes Solutions (Allan Chen)  
Simusolar (V. Vaidya)  
Solaris Offgrid (Benjamin David)  
Solarworx (Felix Boldt, Jakob Schily)  
Sun King (Martin Sun)  
SUNami Solar Kenya (Godfrey Simiyu Katiambo)

CLASP (Elisa Lai, Ari Reeves, Makena Ileri, Riley Macdonald)

Open DC Grid (Jim Gula, Martin Jäger)

University of Twente (Jelena Popovic)

Valuon Strategic (Vimal Mahendru)

VeraSol (Arne Jacobsen, Tom Quetchenbach).

## Disclaimer

At various points in this document, links are provided to specific products. These links are provided as an indication of one possible source of the product, and are not intended to imply any endorsement or suitability of any particular product.

# Connector & Electrical Technical Guidelines

## to enhance 12V Solar Home System and Appliance interoperability

### Contents

<b>1. Introduction</b> .....	<b>8</b>
1.1. Purpose and Status of this document .....	9
1.2. Managing User Expectations.....	10
1.3. Necessary and Sufficient Requirements .....	10
1.3.1. Rudimentary Diagnosis.....	11
1.4. Limitations.....	12
1.5. Scope of this Document.....	12
1.6. Systems Integration .....	13
1.7. Numbering of Guidelines.....	14
1.8. Structure of this Document.....	15
1.9. Derivation of this Document .....	16
1.9.1. Other Source Documents .....	16
<b>2. Glossary and Abbreviations.....</b>	<b>18</b>
<b>3. Electrical &amp; Connector Guidelines for a 12V Supply Socket.....</b>	<b>22</b>
3.1. Supported Options for 12V Supplies .....	22
3.2. Output Port Voltage Range [SV].....	22
3.2.1. Maximum Output Port Voltage .....	23
3.2.2. Minimum Output Port Voltage .....	23
3.2.3. "Low-voltage" Modes .....	24
3.2.4. Switching between normal/low-voltage/under-voltage modes.....	24
3.2.5. Exceptional Steady-State Overvoltage .....	25
3.2.6. Transient voltages and supply stability.....	25
3.3. Available Steady-State Power [SP].....	25
3.4. Available Steady-State Current [SP].....	25
3.4.1. Protecting Equipment against Overload [SO] .....	26
3.4.2. Overload Detection .....	28
3.4.3. Parallel sockets.....	33
3.5. Protection of SHSs against misuse [SM] .....	33
3.5.1. Connection of Output Ports to Power Sources or Rechargeable Batteries....	34

3.5.2.	Reverse-Polarity Connection to Power Sources.....	34
3.6.	SHS Application Example.....	35
3.7.	Status Indicators on the SHS [SI].....	36
3.8.	Power Supply Connectors [SC].....	37
3.8.1.	B3.5 Power Socket.....	37
3.8.2.	S3.5 Low-Power Smart Socket.....	38
3.8.3.	B8 and S8 Power Socket .....	40
3.8.4.	Summary – Compatibility between different Connect Affiliates connectors.	40
3.8.5.	USB Type A Socket .....	41
3.8.6.	USB-C Socket - an optional extra, but not a foundation .....	42
3.8.7.	Recessing power sockets.....	43
3.9.	SHS Extras and Accessories [SX].....	43
3.9.1.	Extension leads.....	43
3.9.2.	Selecting Suitable Cable.....	44
3.9.3.	Adapters for using Low-Power Appliances with High-Current Supplies.....	44
3.9.4.	Adapters for different sizes of 5.5mm barrel connector .....	45
3.10.	Labelling of SHS Output Ports [SL] .....	46
3.10.1.	Labelling of SHS Voltage .....	46
3.10.2.	Labelling of SHS connector polarity.....	46
3.10.3.	Labelling for Two Examples of Current-Limiting Architecture .....	47
3.11.	SHS User Manual Guidelines [SU].....	49
3.11.1.	Support for users with limited mastery of international languages .....	49
3.11.2.	Information about SHS Status Indicators .....	49
3.11.3.	SHS Technical Specification Template .....	49
3.11.4.	Connection of inappropriate load appliances .....	50
3.11.5.	Advice concerning Extension Leads .....	51
3.11.6.	Use of SHS as a battery charger.....	51
3.11.7.	Warning against injecting power into an output.....	52
3.11.8.	Advising the user that low-voltage mode is in operation.....	52
<b>4.</b>	<b>Connect Affiliates Guidelines for Appliances.....</b>	<b>53</b>
4.1.	Appliance Operating Voltage Range [AV].....	53
4.1.1.	Appliance Maximum Operating Voltage .....	54
4.1.2.	Appliance Minimum Operating Voltage.....	54
4.1.3.	Appliance Operating Voltage Range .....	54
4.1.4.	Allowance for voltage drop in cables.....	54
4.1.5.	Appliances supporting a low-voltage mode.....	55
4.1.6.	Operating Voltage for LED Lights .....	55
4.2.	Appliance Rated Current [AP].....	55
4.2.1.	Maximum Current if not given on the Ratings Plate.....	55



4.2.2.	Current Rating for Electronic Appliances.....	56
4.2.3.	Current rating for appliances supporting low-voltage mode operation .....	56
4.2.4.	Current Rating for Resistive Appliances.....	56
4.2.5.	Connect Affiliates Standard Current Ratings.....	56
4.2.6.	Load Current/Time Profile & Maximum Continuous Load Current .....	57
4.3.	Appliances and Galvanic separation [AG].....	58
4.3.1.	Current-sharing.....	59
4.3.2.	Signal Noise .....	60
4.3.3.	Signalling Protocols and Galvanic separation .....	60
4.3.4.	Designing out Galvanic separation Issues.....	61
4.4.	Connectors for 12VDC Appliances [AC] .....	62
4.4.1.	B3.5 Basic Low-Power Plug.....	63
4.4.2.	S3.5 Low-Power Smart Plug.....	64
4.4.3.	B8 / S8 High-Power Appliance Plug.....	65
4.4.4.	Minimum Cable Size for Fault Resilience .....	65
4.5.	Labelling on appliances [AL].....	66
4.5.1.	Appliance voltage labelling .....	66
4.5.2.	Low-voltage mode.....	67
4.5.3.	Appliance peak operating current.....	67
4.5.4.	Connector polarity labelling.....	67
4.5.5.	Efficiency Labelling.....	68
4.6.	Status Indicators on the appliance [AI].....	69
4.7.	Additional Information for the Appliance User Manual [AU].....	69
4.7.1.	Connecting to an inappropriate supply.....	69
4.7.2.	Daisy-chained appliances .....	70
4.7.3.	Advising the User how to Avoid Galvanic separation Problems.....	70
4.7.4.	Appliance Technical Specification Template.....	71
<b>5.</b>	<b>Testing – General Recommendations [T].....</b>	<b>74</b>
5.1.	Testing Environment.....	74
5.2.	Testing to the Technical Specification.....	74
5.3.	Testing of connectors.....	75
<b>6.</b>	<b>Electrical Test Procedures for Solar Home System Output Ports.....</b>	<b>75</b>
6.1.1.	SHS Output Voltage Test Procedures.....	76
6.1.2.	Testing Output Current [SP,SO].....	79
6.1.3.	Testing Outputs for electrical challenges [SM].....	79
6.1.4.	Testing of Status Indicators [SI].....	80
<b>7.</b>	<b>Electrical Test Procedures for Appliances.....</b>	<b>80</b>

7.1.1.	Setting the most demanding conditions for appliances.....	81
7.1.1.	Voltage Testing – General Considerations.....	81
7.1.2.	Minimum operating voltage test.....	82
7.1.3.	Maximum operating voltage test .....	82
7.1.4.	Testing barrel plug dimensions .....	82
7.1.5.	Checking barrel plug polarity.....	83
7.1.6.	Appliances supplied with/without a power coupler.....	83
7.1.7.	Output variation between highest and lowest operating voltages .....	83
7.1.8.	Non-Operating Voltage Tests.....	84
7.1.9.	Testing appliance current.....	85
<b>8.</b>	<b>Appendix I – Battery Voltage and Output Terminal Voltage .....</b>	<b>86</b>
<b>9.</b>	<b>Appendix II – International Standards applicable to SHS systems .....</b>	<b>89</b>
<b>10.</b>	<b>Appendix III – Testing of Connectors.....</b>	<b>92</b>
10.1.	Reference Connectors.....	92
10.1.1.	Definition .....	92
10.1.2.	Use.....	92
10.1.3.	Selection .....	92
10.2.	Testing.....	92
10.2.1.	Testing Objectives.....	93
10.2.2.	Testing of Sockets .....	93
10.2.3.	Testing of Plug Leads .....	93
10.2.4.	What to test for.....	94

# 1. Introduction

The Connect Initiative aims to catalyse market growth and business model innovation by creating an off-grid electricity supply (OGS) ecosystem in which SHS Kits and appliances are interoperable (i.e. that ensures that one manufacturer's product can work with another's).

The initiative asserts that greater standardization and enhanced interoperability of OGS products can bring benefits to companies, consumers, and the environment. It envisages a market in which both interoperable and proprietary ecosystems can co-exist and compete as part of the commercial landscape. Moreover, we believe that both vertically-integrated and supply chain specialist models can benefit from a more interoperable market without radical changes to their business models.

The initial focus of the Connect Initiative, and the scope of this document, is on the following product categories and uses:

- SHS Kits up to 350Wp (PV module) in-line with Verasol and IEC industry standards<sup>1</sup>
- SHS Kits with 12V outputs;<sup>2</sup> and
- Primarily for household use cases, for loads and appliances up to 100W (and therefore excluding high power applications such as solar water-pumps or agri-processing; and
- For both 'Basic' and 'Smart' loads (where 'smart' is with PAYGo activation and/or device control, and 'basic' is without).

SHS Kit & Appliance schematic, Universal Family of Connectors

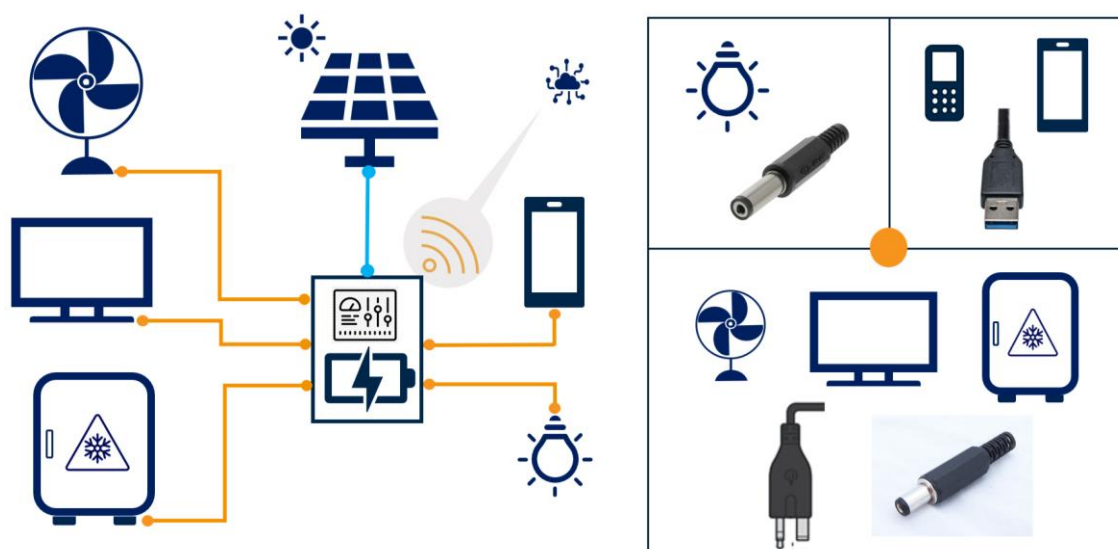

<sup>1</sup> IEC Technical Specification 62257-9-5 and 62257-9-8. [Quality Standards \(verasol.org\)](http://www.verasol.org/QualityStandards)

<sup>2</sup> Based on the VeraSol and IEC 12V definition of 10.5V to 15V.

Ensuring that SHS Kits and Appliances from different manufacturers will work together safely and reliably requires products to meet a set of Technical Guidelines that together form the ‘interoperability stack’; this includes the following layers:

1. Connector;
2. Electrical characteristics;
3. Communications protocol; and
4. PAYGo Activation and Device Control.

#### The Connect Interoperability Stack

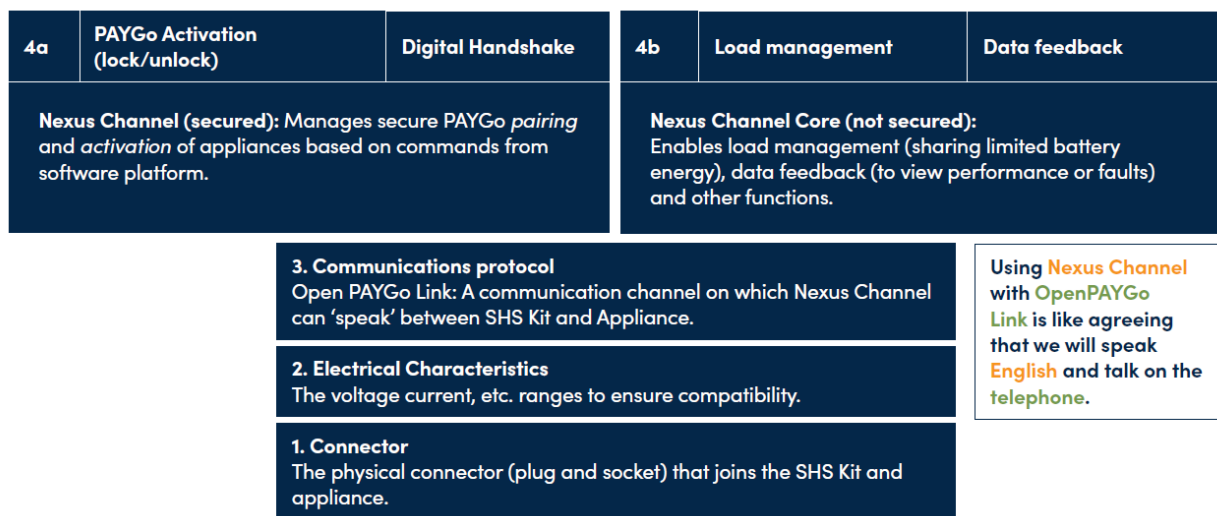

For cash sale products with no device control (‘Basic loads’), it is only necessary to comply with Layers 1 and 2. For products sold on PAYGo and/or with Device Control (‘Smart loads’), it is also necessary to comply with Layers 3 and 4.

This document pertains to layers 1 and 2 of the interoperability stack. Further information on layers 3 and 4 can be found [here](#).

This document refers to ‘Connect Affiliates’, considered to be the manufacturers and distributors who have participated in the creation of these Technical Guidelines and have an interest in pursuing the Connect Initiative business strategy.

### 1.1. Purpose and Status of this document

This document comprises a series of guidelines for Connect Affiliates to adopt. The document is not a mandatory requirement or standard and will not result in a certificate of compliance, though in future this service may offered, subject to demand from the industry.

Every guideline in this document is a recommendation to consider a particular issue, and if technically possible and affordable, to incorporate it in product designs. Eventually, it is hoped that as new products are designed, all Connect Affiliates' product designers will

choose to adopt the guidelines in this document, and thereby ensure their products' compatibility with other products that also adhere to these guidelines.

There are no mandatory requirements, though we will be considering whether some guidelines should become mandatory as part of a subsequent standards document, against which a product may be tested, and with which it will be possible to claim compliance.

## **1.2. Managing User Expectations**

As far as possible, retailers and end-users should be in a position to predict with reasonable certainty based on the information provide whether a particular combination of Solar Home System and Appliance would or would not function as intended.

End-users (and perhaps also retailers, distributors, and wholesalers) are unlikely to have a detailed understanding of electrical characteristics or the design of connectors. They want to know that someone with sufficient expertise has investigated this, and determined what is and is not a satisfactory combination, both from the point of view of system function and system safety.

Confirmation that this work has been done is typically given to the user in one or more of the following ways:

1. A special mark close to the connector on both components that may be plugged together – a mark that is never used on components that should not be plugged together. The mark is associated with connectors on the two components that are able to mate.
2. An unusual connector that can only mate with another unusual connector, and for which there is minimal possibility of either connector being found on non-compliant equipment,
3. For both components, a written statement of compliance with complementary parts (eg supply and load) of the same particular standard (a document to which the user does not need to have access).

This document does not deliver any of the above, but subsequent documents may.

## **1.3. Necessary and Sufficient Requirements**

This document aims to define a particular electrical and mechanical interface between a Solar Home System and an appliance that will deliver the following benefits to the end user:

- A high probability of any combination of compliant SHS and appliance(s) working together, and a reasonable probability of grey market appliances (with the same connector) also working,
- As clear and easily understood boundaries as possible to what is and isn't OK – however there is an unavoidable limitation to this in that:
  - We cannot ensure the functioning of grey market appliances, and
  - The user will have to do arithmetic on current, power, and energy to determine if it will work, and if the runtime will be reasonable
- Where we do not succeed in communicating the boundaries to what is OK, and users try something that is not OK, compliant equipment will not be damaged or become unsafe (although grey market appliances might)

To achieve this, guidelines are defined that may require product changes to enhance or clarify:

- **Flexibility:** Design changes to maximise the consumer's choice (particularly of appliances)
- **Designed boundaries:** Design changes to clarify the boundary of what you can and can't do
- **Documented boundaries:** Additional labelling and user documentation to help the user/distributor determine whether any combination will work
- **Robustness:** Design changes to minimise the chance of equipment damage when we fail to make the boundaries clear
- **Rudimentary Diagnosis:** (see below)

Of course, some design guidelines contribute to several of these objectives.

#### 1.3.1. Rudimentary Diagnosis

The introduction of the flexibility to use many different appliances opens up many possibilities for the reason why a particular combination will not work. It is highly desirable that the user is supported with visible or audible indication of whether an appliance is not functioning because:

- a) It is electrically incompatible
- b) The SHS is in some particular state (for example a low-voltage mode)
- c) Something has been damaged or otherwise failed

This is important, as each has a different remedy. It is doubly important, as now several suppliers may be involved, which creates greater need for less ambiguous problem identification and trouble shooting. Section 3.7 gives details of the guideline indications for an SHS.



## 1.4. Limitations

This document is complementary to the VeraSol certification and associated IEC standards 62257-9-5 and 62257-9-8, and the quality standards for solar appliances, which represent the full specification for a product.

There are many important aspects to assure the quality, safety, durability, and performance of SHS Kits and appliances that are *not* in the scope of this document, including:

- What should be communicated to an independent testing agency
- The Testing and Sampling regime
- Environmental requirements
- The effectiveness, energy efficiency or safety of appliances
- Durability, sustainability, repairability
- USB and smartphone charging (beyond highlighting the issue)
- Protocols for smart loads (a future Connect Affiliates document)
- Conducted and radiated electrical noise (both generating, and having immunity to)
- Appliance ride-through time
- Anything relating to solar panels or SHS inputs
- The ability or otherwise of an appliance to be powered directly by a solar panel (ie without an intervening battery or charge controller)

To ensure good quality and consumer satisfaction it is paramount these aspects are also considered. There are applicable international standards covering these issues (a partial list is given in §9 – Appendix II), and it is a guideline that these are complied with.

Increasingly, product longevity (whether the equipment will degrade over an unreasonably short time to the point where it ceases to be able to operate correctly) is a concern in our marketplace, but that is also not covered in this document.

This document describes recommendations for good practice, but it is not a substitute for a product quality standard, and is not intended for use in isolation.

## 1.5. Scope of this Document

This document is only concerned with the interface between an SHS and an appliance; it pertains to the connectors and electrical parameters of both the SHS Kit and appliances. It is complementary to the VeraSol certification and associated IEC standards 62257-9-5 and 62257-9-8, and the quality standards for solar appliances. It defines an interface between an electricity supply system supplying up to 100 watts of electrical power at a nominal 12VDC, and a load or a number of loads.

It defines both the mechanical and electrical characteristics of the supply-load interface, as both are necessary to ensure interoperability.

The nominal 12VDC focus follows the predominant technology in the off-grid solar market. Future guidelines may consider other low voltage DC levels such as 24V or 48V.

The 100W upper limit on the output has been determined as a reasonable level based on the power ratings of domestic appliances on the market. (Note that the 350W limit of the VeraSol certification relates to the input power for the PV module.)

It specifically excludes consideration of stored energy in an SHS, and the probable run-time of a particular appliance when powered by that SHS. This may be the subject of a future study and guidance document to be developed by this group.

It also specifically excludes any consideration of digital signalling between the supply and the load, for example for the management of PAYGo functionality or demand management. (This is considered in the firmware layers of the interoperability stack as presented in the [Connect White Paper](#).)

Special-purpose ports tailored to a specific load (for example PWM lighting controllers) ([-9-5] Annex EE.4.2.5) are also excluded – this document is only concerned with general-purpose ports that a user may plug a selection of appliances into.

## **1.6. Systems Integration**

Systems integration is the process of connecting different components into a single larger system that functions as intended.

An essential role of the system integrator is to ensure a suitable match between the SHS Kits and Appliance/s. Components must be sized and rated appropriately, so that the system is able to perform its task properly, but also that it isn't needlessly large and expensive. This requires ensuring that the components are electrically and physically compatible (voltage, current, power, connectors), and also that the stored energy results in reasonable run times. This document only concerns itself with electrical and physical compatibility. Although energy compatibility is extremely important for system sizing, discussion of this is reserved for a future document

Systems integration may be done by a manufacturer, distributor, or an end-user. Of course, manufacturers and distributors will have an understanding of electrical and physical compatibility, and provided with sufficient information should be able to select a SHS and appliance combination that perform well together. When an end-user chooses an appliance from another supplier to use with their system, they are taking on the responsibility of doing the systems integration themselves – though they may not fully appreciate this.

The simplest and most intuitive user philosophy with respect to electrical connectors is, "*if it looks the same, it'll behave the same*". This is by-and-large achievable for grid electricity, but off-grid systems have limited power and energy, and it is unavoidable that the user will have to cope with this. Even if it were practical for every SHS power output port of a

certain type to have the same power output capability, the amount of stored energy behind it, and hence how long that power could be delivered for, will differ between systems. Users will have to learn to manage both the power and energy limitations of their system.

If there is a possibility that the user will configure their own system, they should be provided with sufficient information to be able to do it. The documentation provided with each component of the system should be adequate in this regard.

Application of this document to both SHS and appliance should mean that provided the Systems Integrator heeds the ratings plate information provided on each product, and there are sufficient SHS sockets of the correct type, the appliance will function as intended when powered by the SHS.

### **1.7. Numbering of Guidelines**

Guidelines are numbered. As further revisions of this document and the Summary are produced, these numbers will not change. Guidelines are given two letters, assigned as follows:

The first letter is:

- S – Guidelines relating to Solar Home Systems and other off-grid electricity Supplies
- A – Electrical Appliances

A second letter indicates:

- V – Voltage
- P – Power and Current
- O – Overload Protection
- M – Protection against misuse (SHS only)
- I – Status Indicators
- G – Galvanic separation (appliances only)
- C – Connectors
- L – Labelling of ports
- U – User Manual information
- T – Testing

The two letters are followed by a number – for example, "AL.3" refers to the third guideline concerned with the labelling of appliances.

The order of these sections has been changed from earlier versions of the documents, to more closely represent the stages within the product design process at which each factor needs to be considered:

- At Product Design time
- Product packaging and labelling
- Authoring the User Manual
- Testing the product.

## 1.8. Structure of this Document

**Section 2** provides a glossary of terms and abbreviations with specific meanings in this document.

**Section 3 [S\_]** is intended to assist Connect Affiliates in designing 12V Solar Home System products that will be able to power appliances from other Connect Affiliates and many non-quality-verified market appliances. Electrical characteristics and output connectors are defined, but smart signalling protocols are not.

This section also lists some accessories that it is recommended are made available, to allow the full flexibility SHS application to be achieved.

**Section 4 [A\_]** provides information that Connect Affiliates may use when specifying electrical appliances to be procured for supply as part of an SHS kit. If appliances comply with this specification, they will also be able to be powered by other SHS products that have been designed according to Section 3 of this document. Again, electrical and connector characteristics are defined, but smart appliance signalling is excluded.

**Section 5 [T]** gives general recommendations for product testing.

**Section 6 [ST]** provides information on test methods that SHS equipment designers may use to confirm that their products meet these guidelines.

**Section 7 [AT]** provides information on test methods that electrical appliance designers may use to confirm that their products meet these guidelines.

**Appendix I (Section 8)** provides additional detail on the relationship between battery terminal voltage and the SHS output port voltage.

**Appendix II (Section 9)** includes references to international standards outside the scope of this document that we recommend all products consider and comply with.

**Appendix III (Section 10)** describes a proposed method for establishing the compatibility and performance of connectors.

Sections typically begin with a policy statement on the general strategy that has been adopted, followed by a statement in **BOLD** describing the requirement that should be met if compatibility is to be achieved and adjacent to it on its right a statement justifying and explaining the requirement.

**The left-hand column in bold defines the Guideline.**

**The right-hand column in blue contains a commentary that explains why this is**

recommended, and justifies the choices made.

(Compliance with these guidelines is much more likely if designers and manufacturers understand why they have been included.)

Where appropriate, procurement suggestions are given in a section in maroon.

## 1.9. Derivation of this Document

The IEC Technical Specifications 62257-9-5 ([9-5]) and 62257-9-8 ([9-8]) that were developed by VeraSol (formerly Lighting Global Quality Assurance) for testing and certifying Solar Energy Kits underpin this document. However, they do not provide specific performance limits with which a supply on its own or an appliance on its own should comply – rather they are intended to apply to a complete Solar Home System comprising supply and load(s).

This document provides those limits for the very specific context of a Solar Home System with a nominal 12VDC system voltage, and independently, the electrical appliances that may be used with it.

Defining technical guidelines for interoperability between the SHS Kit and appliances entails some extensive changes to the way the Verasol documents may be applied.

In particular, where [9-5] or [9-8] offers several options, only certain options are applicable to SHS and appliances when considered separately. The option to be used is indicated.

There are many sections of [9-5] and [9-8] that can only be applied to a complete system including supply and appliances considered together. Where this applies, it is usually obvious, and the sections are not itemised here.

Several sections of [9-5] and [9-8] relate the energy efficiency or effectiveness of certain appliances (notably lighting). These are out of scope of this document.

### 1.9.1. Other Source Documents

The following documents have also been referred to in the creation of this document:

[VeraSol Consumer Information, Performance Reporting, and Component Labeling Requirements](#)

[Quality Assurance for Off-Grid TVs and Fans: Lessons Learned and Paths Forward \(verasol.org\)](http://verasol.org)





## 2. Glossary and Abbreviations

A glossary is provided of words, phrases and abbreviations used in this document, where the definition differs from the IEC, or is absent.

[-9-5]	IEC TS62257-9-5:2018
[-9-8]	IEC TS62257-9-8:2020
Appliance	This documents uses the term Appliance to refer to all electrical loads below 100W, including lights, mobile phones, fans, TVs, etc.
Barrel connector	<p>A coaxial 2- or 3-pole plug or socket for the delivery of ELVDC power.</p> <p>Note: The distinction between 'plug' and 'socket' and between 'male' and 'female' connectors may be confusing when barrel connectors are involved. Some people refer to plug and socket based on the gender of the central contact (ie the opposite way to the sense used in this document).</p>
Basic	Power only, without associated data communications (in contrast to Smart)
B3.5, B8	The Basic 3.5amp or 8amp interface defined in this document, without communications
Connect Affiliates	Manufacturers and distributors whose products adhere to the Connector and Electrical Technical Guidelines.
Connector	A plug or socket, so designed that when mated with the corresponding socket or plug, an electrical connection is made. (A connector may also be a device for making an electrical connection between two wires without being separable, but it is not used in this sense in this document.)
Coupler	A detachable power lead for delivering power from a fixed socket on a supply to a fixed connector on the appliance, with connectors on both ends, and length not exceeding 2m. This coupler is the 12VDC equivalent of the familiar mains couplers defined in IEC 60320.
DUT	Device Under Test
Fixed (socket, plug)	A connector firmly attached to, or integral with, a product (cf Free)
Free (plug, socket)	On the end of a lead, so that it may be mated with a fixed socket/plug on a piece of equipment. An extension lead has a free plug on one end, and a free socket on the other. (Free may mate with fixed or free, but fixed cannot usually mate with fixed.)

Galvanic Separation	Prevention of electric conduction between two electric circuits intended to exchange power and/or signals Note – Galvanic separation can be provided e.g. by an isolating transformer or an opto-coupler [ IEV 151-12-26]. “Galvanic isolation” is also commonly used.
Guideline	A recommendation that may subsequently become mandatory as part of a product standard.
Grey products	Products that have not been quality-verified by Verasol, including off-brand and unbranded products. (They may have been certified according to other standards than in scope from Verasol – e.g. mandatory national standards on electrical safety).
IEV	The International Electrotechnical Vocabulary, IEC 60050, freely accessible at <a href="https://www.electropedia.org/">https://www.electropedia.org/</a>
OGS	Off-Grid Supply System for electricity
Lump-in-line power supply	A low-voltage power supply designed to have flexible leads for both input and output – for example:



(This example is intended to be used with an IEC 60320 mains coupler.)

Output Port	Connector (typically a socket) on a component that is capable of supplying power to an appliance (cf [-9-5])
Plug	<p>A plug (sometimes a 'jack plug') is a connector, having one or more exposed, unshielded electrical terminals, and constructed in such a way that it can be inserted snugly into a receptacle (socket) to ensure a reliable physical and electrical connection (cf Socket).</p> <p>In the usage in this document, a barrel connector plug has a large exposed cylindrical contact surface, a hollow internal receptacle and is almost always "free" (qv).</p> <p>The significant parameters associated with a barrel connector plug are:</p> <ul style="list-style-type: none"> <li>• Outside diameter of the plug,</li> <li>• Inside diameter of the plug,</li> </ul>

- The diameter of the central gold pin, if any
- The length of the plug barrel (9.5, 10 or 12mm)
- The current-carrying capacity when mated with the approved socket,
- The style of the central contact (turned-pin or tuning-fork)
- The wire entry direction (in-line or right-angle)

Plug-top power supply

A low voltage wall-mounted power supply designed to plug directly into a wall socket – for example:



S3.5, S8

The Smart 3.5amp or 8amp interface defined in this document, including communications

SHS

Solar Home System – a self-contained electricity supply system comprising solar panel(s), solar charge controller, battery and one or more sockets for connecting appliances. The system may consist of separate components or be contained in a single box.

SHS Kit

A kit comprising a Solar Home System and a number of matched appliances

Smart

Power and communications, e.g. for PAYGo activation and / or device control.

Socket

A socket (also sometimes referred to as a "jack") is a connector having one or more recessed holes with electrical terminals inside, and constructed in such a way that a plug with exposed conductors can be inserted snugly into it to ensure a reliable physical and electrical connection. When the plug is removed, the electrical conductors are not directly exposed, and therefore are not likely to make accidental contact with external objects (cf Plug).

In the usage in this document, a barrel connector socket has a recessed hole containing a central pin or cylindrical contact surface. It is designed to accept a barrel plug and has one or more sprung contacts to make connection with the outside of the plug. It may be fixed (qv) in a product enclosure, or free (qv) on the end of an extension lead.

The significant parameters associated with a barrel connector socket

are:

- Outside diameter of the intended mating plug,
- External diameter of the central pin,
- The style of the central pin (turned pin, split pin or lantern spring)
- The current-carrying capacity when mated with the approved plug (mostly a factor of the number of contact springs contacting the plug barrel)
- The mounting and connection method
- Whether a contact is included that is broken by the insertion of a plug

**Systems Integrator** Systems integration is the process of connecting different sub-systems (components) into a single larger system that functions as one. In this context, the Systems Integrator is whoever takes responsibility for matching the SHS and the appliance, and determining their mutual compatibility. This may be the manufacturer (as today), the wholesaler or distributor, or the end user.

**TWG** GOGLA Technology Working Group

**Wall-wart power supply** (See Plug-top power supply) This phrase is sometimes used in North America to describe a wall-mounted or plug-top power supply.

# Solar Home Systems

This section of the document primarily provides guidelines for the design of 12V Solar Home Systems, but it may also be applied to other products designed to deliver power for the operation of 12V appliances.

## 3. Electrical & Connector Guidelines for a 12V Supply Socket

### 3.1. Supported Options for 12V Supplies

Several power output options are included within this guideline. Connect Affiliates may implement any or all of these, in any quantity on an SHS product. This need not necessarily relate the power or energy capacity of the supply, but designers should be aware that putting a certain number of sockets on a product is likely to suggest to the user a capability to power than number of appliances.

- B3.5 – a basic power port capable of delivering up to 3.5amps,
- S3.5 – a smart power port capable of delivering up to 3.5amps,
- B8 – a basic power port capable of delivering up to 8amps,
- S8 – a smart power port capable of delivering up to 8amps,
- USB Type A
- USB-C (option)

Several ports of the same type may be connected in parallel, and share the same overall current limit (there are implications of doing this – see §3.4).

The current limits given here are maximums – for example, a low-cost SHS might only be capable of delivering 1amp through a B3.5 socket (or even a B8 socket, though that would be a bit misleading), and this is acceptable and compliant – provided it is labelled and documented appropriately.

### 3.2. Output Port Voltage Range [SV]

It is clear that there should be agreement between the supply and the appliance on the operating voltage. The appliance should be capable of operating correctly over the entire range of voltage that the supply can deliver – not just at the nominal 12V.

To be certain that the specified voltage range of an SHS is the range that an attached appliance will experience, voltage is measured at the output ports of the SHS, rather than at the battery. Indeed, how the output voltage relates to the battery terminal voltage is not important to the user. (As the relationship between the two is of critical importance to the system designer, a discussion of this included in Appendix I.)

Defining a narrow permissible output voltage range will restrict the designer's choice of battery, but make designing appliances easy. Conversely, a large voltage range will give

greater flexibility of battery chemistry, and even the number of cells, but will make designing appliances difficult. A compromise should be found.

The output port voltage range defined in [-9-5] Table EE.3 is 10.5V – 15.0V. However, note that this voltage range should be met unconditionally – whenever the SHS is used with appliances that are within the spec of §4. For this reason, the tests defined above are more stringent than those in [-9-5] and [-9-8].

(If the SHS includes voltage conversion or stabilisation, these voltage range requirements should easily be met.)

The requirements of [-9-8] §5.3.6.1 are tightened – the output voltage range should always be within the range 10.5V – 15.0V, and not merely overlap with it at some point.

In recognition that any appliance may be powered from this product, the provisions of [-9-8] §5.3.6.2 should not apply.

Exceptionally, SHS products employing 3-cell NMC batteries will not be able to meet this voltage range. To indicate that this is the case, it is a guideline that these products are not described or labelled as "12V", but rather "11.1V", as mandated by Verasol. This puts the user on notice that appliances labelled as "12V" may not function correctly.

### 3.2.1. Maximum Output Port Voltage

The highest terminal voltage  $V_{\max}$  will occur when the charging current ( $I_{\text{charge}}$ ) is the highest it can be with the provided solar panel(s), the battery is nearly fully charged and the load current through all the ports is minimal. This is also likely to be highest when the battery is approaching the end of its useful life, and the internal resistance is at a maximum (unless the solar charging is at constant voltage). This voltage needs to be known, as appliances should not overheat or their components suffer electrostatic breakdown at this voltage – even when connected but turned off.

<b>SV.1</b>	<b>The output port voltage should not exceed 15.0V (as specified by -9-5 and -9-8) under any foreseeable circumstances.</b>	<b>Higher voltages may cause the appliance to malfunction or permanently damage the appliance.</b>
-------------	---	--

### 3.2.2. Minimum Output Port Voltage

When allowance is made for the factors listed above, the minimum output port voltage may be significantly lower than the battery terminal voltage. The lowest terminal voltage  $V_{\min}$  will occur when the charging current ( $I_{\text{charge}}$ ) is zero, the battery is nearing the end of its useful life, its charge is nearly exhausted and the output port(s) are all drawing their rated currents ( $I_{\text{load}}$ ).



This voltage needs to be known, as appliances as designers of appliances need to know the minimum operating voltage (which should be at least 500mV below this).

- SV.2** The output port voltage should not fall below 10.5V (as specified by -9-5 and -9-8) under any foreseeable circumstances, unless the SHS indicates visibly or audibly that it is operating in a low-voltage mode.
- Lower voltages may cause the appliance to malfunction.

### 3.2.3. "Low-voltage" Modes

Some SHS products incorporate a "Low-voltage" mode of operation, in which when the stored energy in the battery is nearly exhausted, certain higher-power output ports are disabled. In this mode, the output voltage may be lower than normally permitted.

- SV.3** A clear visual indication should be given (eg a flashing battery level LED) to indicate that low-voltage mode is in operation.
- So a user can tell that it is not simply that an output port or appliance has failed.
- SV.4** In low-voltage mode, the terminal voltage should not fall below 9.0V.
- Designers of appliances able to operate in low-voltage mode must have a minimum operating voltage to design to.

### 3.2.4. Switching between normal/low-voltage/under-voltage modes

As a depleted battery is recharged by its solar panels, its voltage will rise very slowly. When the voltage becomes sufficient for normal operation to be restored, the loads will be reconnected, current will be drawn, and the battery voltage will fall again slightly. If the voltage at which power is restored is the same as the voltage at which it is cut off, the power will flicker as the voltage gets to this point. This may be avoided by building in some hysteresis.

- SV.7** When the battery is discharging, the cut-off voltage at which low-voltage mode or under-voltage take effect should be lower than the voltage at which power is restored during charging. A difference of 50mV is suggested.
- This will eliminate flicker at this point.

### 3.2.5. Exceptional Steady-State Overvoltage

There may be exceptional circumstances in which the output voltage is no longer determined by battery chemistry, and it is essential that if this occurs, no harm occurs to users, or damage to appliances.

Overvoltage may occur if the battery becomes disconnected or open-circuit due to an internal fault while charging current is being supplied. The test of [-9-5] §DD.4.3.5 Procedure B should be applied in every case where the conditions of [-9-5] §DD.4.3.1 are not met, and ideally in all cases.

- SV.5** Where applicable, the Exceptional Steady-State Overvoltage Upper Limit – Battery Disconnect Test specified in [-9-5] Annex DD §4.3 should pass. If a battery becomes disconnected, it is important that it doesn't damage any connected appliances.

### 3.2.6. Transient voltages and supply stability

If a DC-DC converter is present between the SHS battery and an output port, the voltage response to sudden current demands is likely to be important. This will always be the case for USB ports, but it may apply to others too. Procedures for ensuring that feedback loops are unconditionally stable are given in §6.1.1.7.

- SV.6** Where a DC-DC converter is present between the battery and an SHS output port, the transient response should be studied, and determined to be unconditionally stable. Certain loads or combinations of loads may cause the output voltage to oscillate. This may be very damaging to both SHS and load(s).

## 3.3. Available Steady-State Power [SP]

A power supply port of finite capacity may have its limitations expressed as a maximum power or a maximum current. (The two are not equivalent, as the voltage may vary significantly.)

It is therefore a guideline that Rated Current be used as the limiting indicator, as in general the heating effect in semiconductors, connectors and cables is related to current, rather than delivered power. This value should be used in testing, labelled clearly on the SHS product as described in §3.10.3 below, and quoted in the User Manual and Technical Specification.

## 3.4. Available Steady-State Current [SP]

- |  |  |
|--|--|
| <p>SP.1 B3.5 and S3.5 output ports should have published maximum steady-state current ratings no greater than 3.5amps (but may be less). This may be the total current for a group of B3.5/S3.5 ports connected in parallel.</p> | <p>Many barrel connectors are unable to conduct a greater current than this.</p> |
| <p>SP.2 B8 and S8 output ports should have published maximum steady-state current ratings no greater than 8.0amps (but may be less). This may be the total current for a group of B8/S8 ports connected in parallel.</p>         | <p>We are currently restricting ourselves to SHS products under 100watts.</p>    |

In order to avoid the need for the user to do "current arithmetic" for working out which combinations of appliances can be used together, it would be necessary for an output port to the B3.5/S3.5 specification to deliver 3.5 amps continuously under all circumstances (except of course when turned off or the battery was exhausted). Equally, a B8/S8 port would always be able to deliver 8amps.

It will probably be necessary for low-cost products to be sub-equipped, and there will be a need for the user to study the ratings plates on the SHS and intended appliances to understand what they have.

Consequently, a B3.5/S3.5 port may not be capable of delivering 3.5 amps continuously (or at all), but we can say it will not continuously deliver more than approximately 3.5amps+20% under any circumstances, and the user should not expect to be able to power an appliance that states on its ratings plate that it needs more than 3.5amps. In other words, it is permissible for a B3.5/S3.5 socket to only be capable of delivering (say) 1amp continuously, provided that this is clearly labelled on the product and documented in the User Manual.

Equally, it should be evident that if a number of ports are connected in parallel and a total current of 3.5amps is specified, if there are already loads connected rated 3amps total, it is possible than an additional load with a ratings plate current of 1amp *may* overload the system. (It also may not, because a load may only take its rated current for a very short period. As long as all the loads don't take their rated current simultaneously, everything may well work correctly.)

#### 3.4.1. Protecting Equipment against Overload [SO]

To prevent overloading the SHS causing damage, several options exist:

- a) Blow a fuse, which should be replaced after the fault has been rectified.

- b) Limit the current to the maximum that the SHS can sustainably deliver,
- c) Reduce the current to a low level until such time as the impedance of the load increases to an acceptable level ("foldback current limiting") – this could be implemented electronically, or less desirably using a self-resetting PTC thermal fuse – or
- d) Trip the system, turning off the electricity supply to the port or group of ports, and require the user to intervene and manually reset the system,

The oldest solution (a) is simple and low-cost, but should be avoided. The user is very unlikely to have the correct replacement fuse, and may resort to tin foil, a nail or paper clip or worse. The user has no way to know before replacing the fuse whether they have correctly remediated the fault that caused the fuse to blow, and if they do replace the fuse with the correct value, it may well blow again.

Of the remainder, (b) is the simplest to implement, but it has the disadvantage that the current into the appliance or fault remains at a high level. Heat dissipation in the SHS, the appliance and the intervening wiring may be high, and the wiring may overheat and be damaged. This also is deprecated.

Solution (c) solves this problem, but in the case of an over-demanding appliance, the low current and voltage may cause the problem to disappear. The SHS will after a short while restore the power, and the problem will repeat, with a cycle time of a few seconds. This can be very irritating to users.

The PTC thermal fuse is better in this respect, in that the cycling will take up to a minute, but that may be sufficient time to confuse the user, who may think the product has failed. If this approach is adopted, some visible indication should be provided to the user that this is what has happened.

Solution (d) is generally preferred, as it clearly indicates the problem to the user, who is then able to identify and remediate the situation, in several steps if necessary.

In every case, current limiting causes all appliances that share the current-limiting circuitry to shut down. A single current limiter for all output ports has the disadvantage that any fault will put the entire house in darkness, and perhaps make remediation difficult.

#### 3.4.1.1. Why is Overload Tripping Highly Desirable?

It may be argued that the complexity inherent in requiring a manual reset – and the consequent need to ensure that nuisance tripping doesn't occur – is unnecessary. Surely one could simply reduce the current/voltage to a low level, and wait for the condition to disappear?

There is no doubt this will effectively prevent damage to the SHS. However, most loads are now electronic. They require a certain minimum voltage in order to present any load at all to the supply. Reducing the voltage in order to reduce the load current is likely to

make the load current disappear completely. (This is especially likely with foldback current limiting.) The cause of the overload disappears – but it is still connected. If the voltage is restored without a manual reset, the overload will reappear and the cycle will repeat.

Cycling power on and off is extremely irritating to the user, especially as the frequency will be indeterminate and may be irregular. It's often between 0.5Hz and 3Hz.

The irritation may be reduced by having separate current limiting for appliances and lights. However, the behaviour of appliances under these conditions is extremely uncertain and may result in permanent damage.

### 3.4.2. Overload Detection

When a new load is connected to an electricity supply, it is usual for a large current to be taken initially – typically significantly larger than the current indicated on the ratings plate. This 'inrush current' may only last microseconds, or in the case of a large motor getting up to speed it may be up to a second or more. This presents the equipment designer with two challenges:

- a) To deliver the inrush current to the load for as long as necessary, without the supply voltage dipping excessively or tripping any circuit protection,
- b) To differentiate inrush current from fault/overload current (in the latter case, the load should be disconnected as quickly as possible, to avoid disrupting other attached loads or needlessly discharging the battery).

As the supply has no prior knowledge of the magnitude or duration of the inrush current a load may present with, the designer needs some figures to work with. If these are too high, the supply equipment will be unnecessarily expensive to manufacture, but if too low, a valid load will be treated as a fault.

It is important that inrush currents do not cause an overload/overcurrent detector to trip and require a manual reset.

#### 3.4.2.1. [A brief tutorial on inrush current in DC circuits](#)

Electrical loads present inrush current when first connected for a number of distinct reasons. Each has its own particular current/time profile:

##### **Capacitance**

This inrush current has the highest magnitude and the shortest duration. It is not uncommon for a load to have a capacitor of 220 $\mu$ F or more across the supply. Unless limited electronically, the current will only be limited by the various parasitic resistance

elements in the circuit – battery internal resistance, semiconductor 'on' resistance, wiring resistance and the equivalent series resistance (ESR) of the capacitor.

### Oscillators

The way in which most oscillators start up is poorly defined. An inverter for example may draw a high load current until properly running – this may take 100ms or more.

### Thermal effects

Tungsten lamps have a low cold resistance. (Resistance of a 60W car headlamp bulb is about 400mΩ when cold, suggesting an initial inrush current at 12V of 30amps). Heating up takes about 200ms.

### Traditional Motors

When power is first applied, the motor is stalled, and there is no back-emf. Current is therefore determined by the winding resistance. A high initial current may be needed to overcome stiction (a disadvantage with current-limiting), and if driving something like a fan, the motor may take a couple of seconds to get up to speed.

#### 3.4.2.2. Overload Detection - Guideline

These are the guideline characteristics:

The short-term peak current is not specified. Manufacturers may choose to limit it electronically (less strain on components, but loaded motors may not start, and there will be longer voltage dips) or not.

Output current should be monitored. (Output voltage may only be used as a proxy for current if electronic current limiting is implemented, as the battery discharge current may be excessive even when the output voltage is within limits.)

A current that decays rapidly to a permissible steady-state value is unlikely to represent a fault.

A current of any value into a load where the voltage is rising rapidly towards normal operating voltage is unlikely to represent a fault.

Therefore, the condition for an overload trip to occur should be either that the current is failing to fall fast enough, or in a current-limited system that the voltage is failing to rise sufficiently fast.

In the following formulae, the symbols have the following meanings:

$V_{port}$ : The terminal voltage measured at the output port of the SHS

$i_{port}$ : The load current measured at the output port of the SHS



- $I_{pk}$ : The peak current – if unlimited, a typical value for this equipment based on connecting a short-circuit may be used. If current is limited electronically, set  $I_{pk} = (5 * I_{rated})$  for the port.
- $I_{rated}$ : The published rated maximum steady-state current for the port or group of ports.
- $V_{min}$ : The minimum permissible steady-state terminal voltage (10.5V)
- $t$ : The time in seconds since the voltage or current went outside permissible steady-state limits
- $T_1$ : Time-constants in seconds. A guideline value of 0.3secs is recommended. (Longer may be needed if large motors are involved, but may cause other connected appliances to misbehave.)
- $T_2$ : Time-constant in seconds. A guideline value of 0.15secs is recommended. It should be less than  $T_1$ .

#### 3.4.2.3. Current-based Overload Detection

Current-based overload tripping should occur if the following condition is met for more than 100 $\mu$ s:

$$i_{port} > (I_{pk} e^{-t/T_1}) + 1.25 I_{rated} \quad (a)$$

....and should not occur if the following condition is met, unless the condition for voltage-based tripping is met:

$$i_{port} < (0.7I_{pk} e^{-t/T_2}) + 1.15 I_{rated} \quad (b)$$

This may be represented graphically as follows:

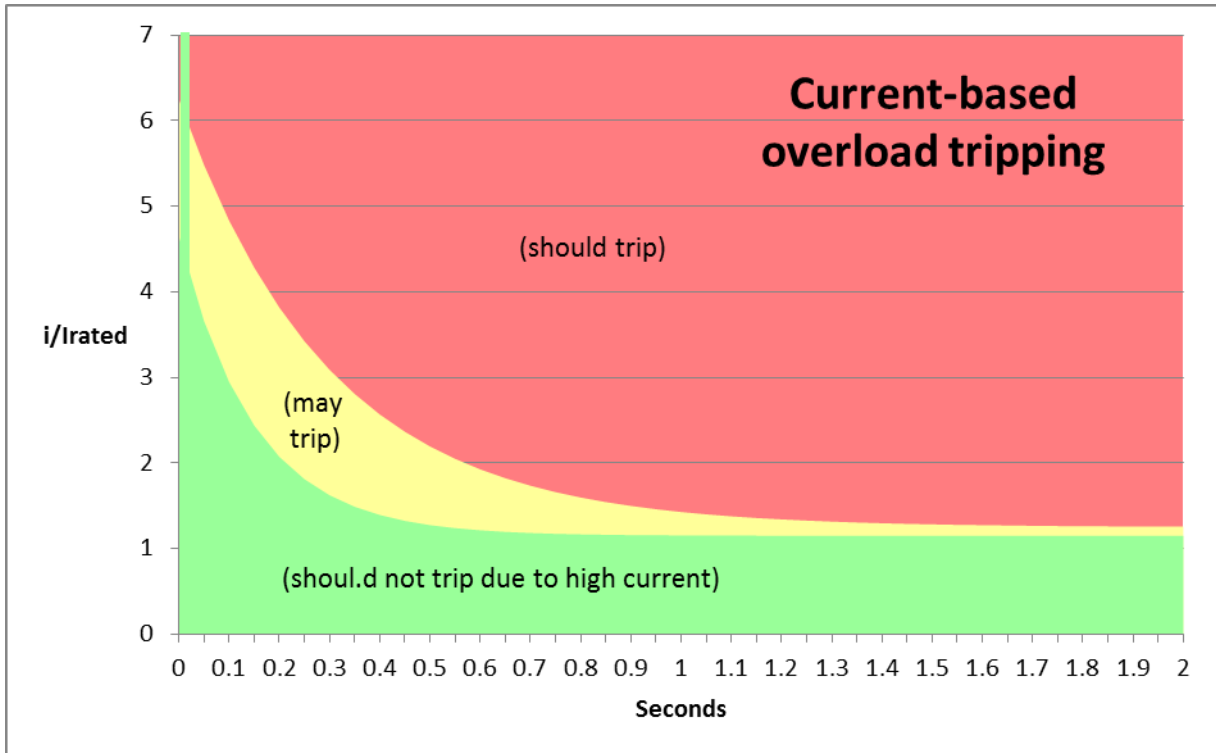

Inrush current.xlsx

(Note that with this algorithm, the 30amp inrush current of the 60W car headlamp bulb mentioned above *might just* cause overload tripping on an 8amp port.)

#### 3.4.2.4. Voltage-based Overload Detection

Alternatively, voltage-based overload detection may be employed if electronic current limiting is implemented.

In this case, tripping should occur if the following condition is met for more than 100µS:

$$v_{port} < (0.95 V_{min} (1 - e^{-t/T_1})) \quad (c)$$

....and should not occur if the following condition is met:

$$v_{port} > (V_{min} (1 - e^{-t/T_2})) \quad (d)$$

This may be represented graphically as follows:

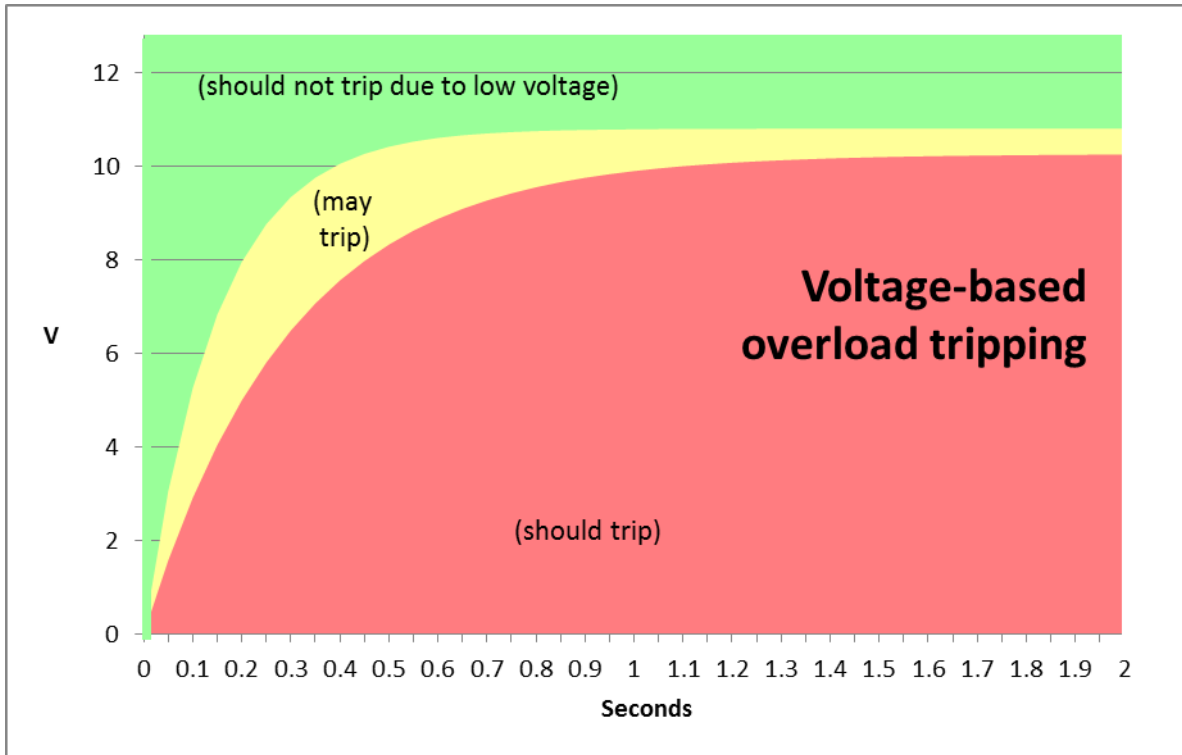

Inrush current.xlsx

If the maximum current is limited electronically to a level not much above the rated current, it may be necessary to increase the time-constants for voltage-based detection to avoid nuisance tripping.

### 3.4.2.5. Overload Tripping – Review

The voltage- and current-based tests are not precision tests – tripping may occur anywhere within a fairly wide range (the yellow areas in the graphs). The tests may be implemented digitally, using an algorithm or stepwise using a lookup table, or using analogue components (eg charging a capacitor as in the example below), or any other method that delivers a tripping boundary between the values defined in the formulae.

Those familiar with thinking in analogue electronics terms may find the following conceptual model of overload tripping helpful:

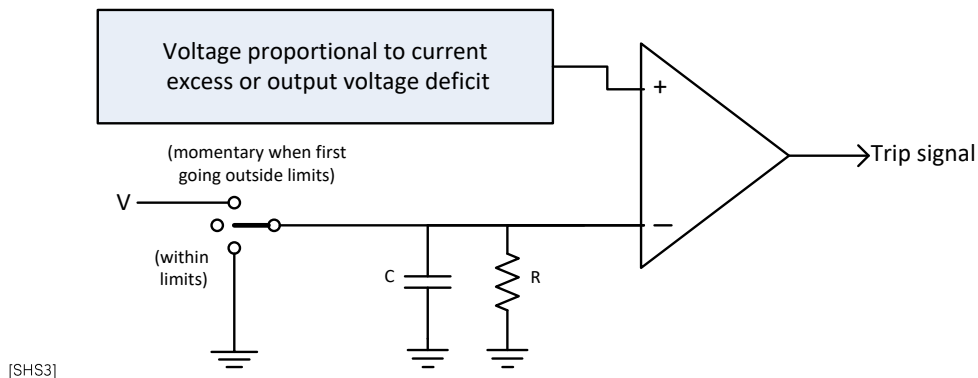

### 3.4.2.6. Overload Tripping – Condition for Compliance

SO.1	Overcurrent protection should kick in if either condition (a) or (c) of §3.4.2.3 is met.	(See explanation in §3.4.2.3.)
SO.2	Overcurrent protection should not kick in if either condition (b) or (d) of §3.4.2.3 is met, unless condition (a) or (c) is met.	This will avoid nuisance tripping.
SO.3	Overloading should cause a trip requiring a manual reset, to avoid power cycling, and indicate to the user that remedial action is required.	Manual resetting will avoid recycling of power during a fault or overload.
SO.4	If output ports are individually controlled by software, when turned on by a master switch they should power up in a set sequence, with a delay of approximately 500mS between them.	Inrush current is likely to occur for all loads simultaneously when the power is first turned on. This will minimise this problem.

### 3.4.3. Parallel sockets

Whether the overload protection is implemented for each individual output port, for a group of ports or for all outputs together is a commercial decision, though clearly it is beneficial for the user if (say) lights continue to operate in the event that some high-power appliance overloads its port.

## 3.5. Protection of SHSs against misuse [SM]

Providing an open system where users are free to source appliances anywhere they choose invites experimentation. Some of these experiments have the potential to damage the SHS. In our market, what an electrical engineer would consider a blatant example of equipment misuse may simply be ignorance.

It is often argued that provided one warns against it in the user manual, the outcome of any misuse is the user's responsibility. This is generally not defensible in law if the potential outcome is to expose the user to risk of injury (eg burns), fire (or in principle, electrocution, though that hardly applies here). Steps to prevent this are considered mandatory for compliance with this document.

It is our guideline that any foreseeable action short of physical misuse that does not involve the use of tools should not permanently damage the product. This includes plugging any plug – including any plug on any grey market product – into a socket into which it appears to fit should not damage the SHS. (We cannot be answerable for what it may do to the grey market product!)

If the potential outcome is equipment damage, there may be a simple business case for the expense of preventing it, if it forms part of a PAYGo service.

The principal form of electrical misuse that is likely is the application of external voltage to an SHS output port. There are two foreseeable ways in which this may occur:

1. An inductive load may suddenly disconnect, causing a large voltage spike
2. A user may attempt to charge a battery with the port, or the user may plug in an external power source, for example a lump-on-the-wall power supply.

Each of these demands a different protection mechanism.

Note that charging a standalone external battery with an SHS may be a legitimate use, if the voltage of the external battery is less than 12V. It is likely that the SHS will go into overload unless the user provides some external control of the charging current.

As SHS output ports are deemed general-purpose, the condition of [-9-5] Annex DD.4.1.4(a)ii should always apply – the output port should be treated as though anything may be plugged into it, and subjected to the miswiring protection tests specified therein.

### 3.5.1. Connection of Output Ports to Power Sources or Rechargeable Batteries

**SM.1 Connecting a power source to any output port of the SHS should not cause power to flow into the battery.**

**This should apply regardless of whether the equipment is turned on.**

This could cause a lithium battery to catch fire, or a lead-acid battery to generate hydrogen.

Turning equipment off may not protect against this type of misuse

Note: As MOSFET switches include an intrinsic reverse-biased diode, complying with this requirement may entail inclusion of an additional MOSFET configured as an ideal diode (see §3.5.2). An alternative, cheaper but less desirable approach might be a crowbar across the output, causing the fuse to blow, if it is protected by a fuse.

### 3.5.2. Reverse-Polarity Connection to Power Sources

An externally-applied negative voltage, if unmanaged, is likely to cause considerable

damage to an SHS. It is customary to protect against this with a reverse-biased diode across the output port.

**SM.2** Connecting a power source to any output of the SHS so as to cause the negative terminal to become more positive than the positive terminal should be clamped at a reverse voltage of no greater than 1.0V, when measured with a current equal to the rated current of the port.

This will normally be achieved using a silicon diode. This is also a requirement for protection against large voltage spikes from inductive loads.

The reverse protection diode should have an  $I_f$  of greater than the fuse value.

**SM.3** If an SHS is considered repairable, a fuse should be provided in the output to protect the reverse-protection diode as well as the rest of the SHS.

As connecting a low-impedance reverse-polarity power source (such as a reverse-connected battery) would cause a large current to flow through the diode, if the product is deemed repairable, this measure will avoid extensive consequential damage.

The fuse should only trip in this situation (since overloads are protected as described in §3.4.2). A narrow fusible printed-circuit track might suffice. This will save a lot of consequential damage, and make the SHS easy to repair.

Optionally, a Zener or avalanche diode may be used, to ensure that the fuse also blows in the event of an excessive positive voltage being applied. Other approaches may be possible.

### 3.6. SHS Application Example

A possible solution to meeting the above requirements is shown below:

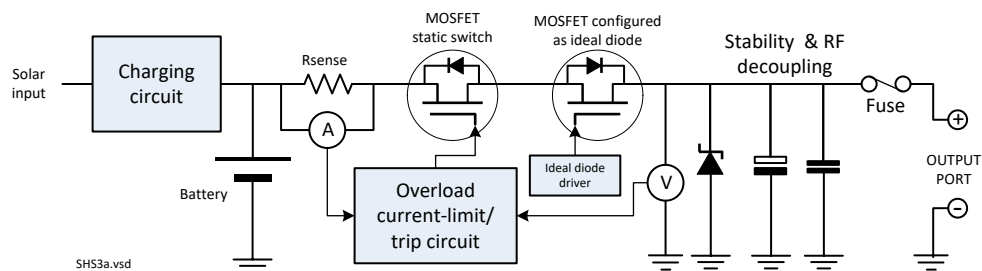

### 3.7. Status Indicators on the SHS [SI]

A SHS is only capable of delivering a limited amount of power, and a limited amount of total energy. (Users are often confused between the two.) They will need to learn how to deal with both these limitations, and understand the difference between them.

The introduction of the flexibility to use many different appliances opens up many possibilities for the reason why a particular combination will not work. It is highly desirable that the user is supported with visible or audible indication of whether an appliance is not functioning because:

- a) It is electrically incompatible
- b) The SHS is in some particular state (for example a low-voltage mode)
- c) Something has been damaged or otherwise failed

This is important, as each has a different remedy. It is doubly important, as now several suppliers may be involved.

- |      |   |   |
|------|---|---|
| SI.1 | The user should be given a visual indication of the following exceptional conditions, rather than simply experiencing the power being turned off: <ul style="list-style-type: none"><li>• Power demand/system current over the permissible limit</li><li>• Equipment overheating</li><li>• Battery failure</li><li>• Battery stored energy nearly exhausted (audible warning also desirable)</li><li>• Battery stored energy exhausted</li><li>• Any other protective measure that is in effect, causing the output to be disabled or in some special condition (eg low-voltage mode)</li></ul> | This will help them to understand that this is an intrinsic limitation of the product, and not a fault. |
| SI.2 | It is highly desirable that a consistent convention is adopted between Connect Affiliates on the visual indicators to be used to indicate the various possible states of the SHS.<br><br>A consensus between the members should define the conventions to be adopted, with options  | This will minimise user confusion when changing brands.   |

depending on how many LED or other visual indicators are on the product.

### **3.8. Power Supply Connectors [SC]**

The off-grid solar industry convention is that supplies are provided with panel sockets, and loads are provided with free plugs. This is the opposite of that usually adopted by LVDC-powered appliance manufacturers who provide plug-top or lump-in-line power supplies with their products. As the plugs used for both are often the same, this different convention reduces the probability of misuse. However, it does leave open a risk that in an area with some kind of grid electricity, a user could plug a plug-top or lump-in-line power supply into an outlet socket. (These power supplies may have a design voltage anywhere between 3.0V and 28V or more, including AC.) This is considered in §3.5.

A lead with free plugs on both ends of the types included in this guideline could encourage a user to attempt to power an unsuitable appliance – for example a 19V laptop from a B8/S8 outlet, or a 3V hair clipper from a B3.5 outlet. Either could result in damage to the appliance.

#### **3.8.1. B3.5 Power Socket**

**SC.1 The socket should be designed to mate with a barrel plug of 5.5mm outside diameter, 2.5mm inside diameter.** [\(See explanation below\).](#)

The low-power basic socket has been selected by the TWG for the Connect Affiliates to be compatible with as large a selection of grey appliances as possible. This dictates the choice of jack sockets that are able to mate with a free 5.5mm outside diameter barrel connector plug on a lead from an appliance. (This is the most popular of at least 59 different barrel connector sizes.)

**The internal pin diameter of the barrel socket jack is defined as 2.5mm.** This connector is sometimes referred to as "5525". Many 12V appliances have compatible 5525 plugs, but there are also many that have 5.5/2.1mm plugs ("5521"). Adapters are widely available to permit these appliances to be used with a 5525 jack socket.

Jack sockets with more than one spring contact to make contact with the outside of the barrel plug are preferred. The performance of connectors should be tested (see Guideline ST.1.)



*NB: for this to be a safe and satisfactory policy, it is clearly essential that the Connect Affiliates move away as quickly as possible from using 5.5mm OD barrel connectors for any other purpose (for example, solar panels or PWM lights).*

#### 3.8.1.1. B3.5 Socket polarity

- SC.2 The polarity of the B3.5 socket should be centre-positive. This is by far the most popular polarity, both in the grey market and among Connect Affiliates.

#### 3.8.2. S3.5 Low-Power Smart Socket

The following socket combination has been selected for low-power (<3.5A) smart connections:

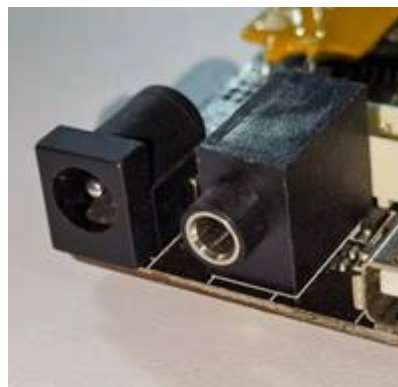

- SC.3 The S3.5 smart socket should comprise a B3.5 socket as defined in §3.8.1 and, at a distance of  $13.5 \pm 0.3$ mm from it centre-to-centre, a 3.5mm audio stereo jack socket. The S3.5 low-power smart socket should accommodate the plug defined in §4.4.2.
- SC.4 The face of the audio socket should be in the same plane as the face of the barrel socket  $\pm 0.3$ mm. This it to ensure that when mated, both parts of the connector are fully inserted

#### 3.8.2.1. S3.5 Low-Power Smart Socket Pin Connections

- SC.5 The connections on the audio jack should be:

- Tip – D+

- Ring – D-
- Shank – GND

Some points to note about this:

- The data lines will be briefly shorted to ground during mating/unmating.
- This convention discharges any accumulated static to the D+ line, which should be suitably protected.
- The digital protocols will be defined in a separate document covering smart appliances.

### 3.8.2.2. Use of paid-off smart appliances with S3.5 plugs with basic B3.5 supplies

It was a design objective that paid-off smart appliances should be usable with basic supplies.

SC.6 At least one B3.5 socket on the product should have a hole at a distance of  $13.5 \pm 0.3$ mm centre-to-centre, to accommodate the 3.5mm jack plug component of the S3.5 plug.

This is necessary for it to be possible to use a paid-off appliance with an S3.5 plug with a basic B3.5 supply. (The hole could be at right-angles to the line of sockets mounted on the printed circuit. This requirement could also be met by the B3.5 socket being less than 10mm from the edge of the enclosure.)

The hole should be at least 16mm deep, 3.8mm diameter and be blind.

This is to maintain the integrity of the enclosure.

The hole should not contain any contacts.

This is necessary to indicate that smart functionality is not supported.

An acceptable alternative would be the provision of an adapter, which could be supplied as part of the process of unlocking a paid-up PAYGo appliance:

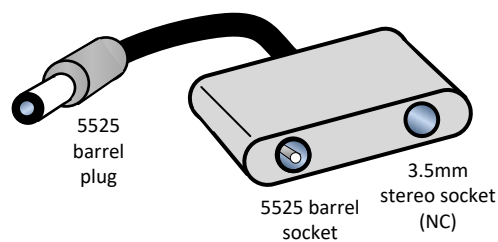

### 3.8.3. B8 and S8 Power Socket

Higher-current barrel plugs generally have larger diameters, and often have a central gold pin. There are many different sizes, mostly developed for powering laptops – but for laptops, the free plug provides the power, and the socket is on the load. The guideline is that the opposite gender is adopted, as this will discourage inappropriate use with a laptop. (This will be invalidated if a lead is supplied with this connector on both ends.)

- SC.7** The power socket for loads up to 8amps should be suitable for a 3-pole barrel plug 7.4mm OD, 5.0mm ID with a 0.6mm centre gold pin (colloquially known as a "7406 jack").
- This has been selected as the preferred high-current socket for both basic and smart supplies up to 8amps.



Procurement information and technical specifications for this connector may be found inter alia at [https://www.foxconn-connector.com/power\\_connector/JPD1135\\_509\\_7F\\_2965.html](https://www.foxconn-connector.com/power_connector/JPD1135_509_7F_2965.html) or <https://www.globalsources.com/si/AS/DongGuan-Dajiang/6008852630956/pdt/dc-jack/1180960679.htm> or <https://www.digikey.co.uk/en/products/detail/cui-devices/PJ-096H/9830159> . (As a cost-saving exercise, it might be possible to procure connectors with the centre gold pin or receptacle omitted, for basic appliances or supplies respectively.)

#### 3.8.3.1. B8 and S8 Socket Polarity

- SC.8** The polarity of the B8/S8 socket should be outside negative, inner positive. The receptacle for the centre pin should be used for signalling in smart supplies, and not connected in supplies that are not smart-capable.
- This is the polarity used by laptops that use this plug. The centre pin will be used for smart signalling, and will be disconnected for basic supplies and loads.

### 3.8.4. Summary – Compatibility between different Connect Affiliates connectors

		Supply socket			
Appliance nlua		B3.5	S3.5	B8	S8
	B3.5	✓	✓	§3.9.3 Adapter req'd	§3.9.3Adapter req'd
	S3.5	If paid off (but see §3.8.2.2)	✓	If paid off §3.9.3 Adapter req'd	§3.9.3 Adapter req'd
	B8	✗	✗	✓	✓
	S8	✗	✗	If paid off	✓

### 3.8.5. USB Type A Socket

USB Type A is the de facto standard for mobile phone charging that is commonly adopted in the off-grid solar market. The standard may be found [here](#). However, the standard includes many variants, particularly with regard to battery charging protocols.

As the percentage of mobile phones that are smartphones increases in the target markets, the need to support smartphone charging is becoming increasingly important. Use for charging tablets may also become significant.

All USB Type A sockets are not created equal; there are many different fast charging protocols and it is a rapidly evolving area. Users typically have no idea about fast charging. This makes it very hard for smartphone users to do anything apart from use the mains charger provided with the phone. (As basic charging of smartphones can take over 24hours, they may well consider current solar lantern and SHS products to be faulty or insufficiently powerful.)

The following options are commonly found on USB Type A sockets:

- 0.5Amps, data lines disconnected
- 2.1Amps, data lines connected to a resistor network (per [-9-5] §EE.4.5.4)
- Fast charging to USB BC1.2
- Fast charging to Qualcomm QuickCharge 1.0/2.0/3.0 ("QC")
- Samsung Adaptive Fast Charge ("AFC")

It is recognised that it is unrealistic to require products adhering to this document's guidelines to support all possible fast charging options.

In summary, if a USB Type A mobile phone charging socket is to be provided on a product, it is a guideline that detailed consideration is given to the range of products it is able to charge in a sensible amount of time. (This supersedes the requirements of [-9-8] §5.3.6.4.2.)

(A useful briefing on fast-charging Apple products may be found at <https://global.ipitaka.com/blogs/news/everything-you-need-to-know-about-fast-charging-your-iphone> .)

### 3.8.6. USB-C Socket - an optional extra, but not a foundation

We see USB-C as important, particularly as it is bound to be a feature of the OGS market in the future, but we think it is not a good foundation for a universal off-grid solar standard.

**Note:** *On 23Sep2021, the European Union issued a directive to smartphone manufacturers requiring them over the next 24 months to migrate to USB-C and a harmonised fast charging protocol – see [https://ec.europa.eu/commission/presscorner/detail/en/IP\\_21\\_4613](https://ec.europa.eu/commission/presscorner/detail/en/IP_21_4613) . Our marketplace will have a very high percentage of legacy phones and smartphones, and we need to develop a strategy to solve this, but this is out of the scope of this document. In the meantime, it should be recognised that the user SHS smartphone charging experience may be disappointing.*

USB-C is a good choice for some SHS business models and markets, but it is not suitable for everyone. This is especially the case in developing countries where USB-C has drawbacks that include:

- There are many functional subsets of USB-C, and no standardised way of indicating which subset has been provided or is expected.
- The connector is small and fiddly; it was not designed for rural Africa where it can suffer with dust, humidity, and extreme heat.
- The connector has 24 pins and a complex set of protocols and voltage levels, which bring additional components, costs and complexity for SHS Kit and Appliances. Field termination of cables is impossible.
- Implementation is expensive; the unit costs are still high and if appliance manufacturers want to use the USB-C logo, they should pay USD 5,000 per year to the USB-C Implementers Forum.
- USB-C-powered appliances are only capable of sharing signal data with other appliances powered from the same USB-C hub, due to galvanic separation limitations (see §4.3).

USB-C does not define a single set of electrical characteristics. A manufacturer deciding to implement a USB-C power port will need to choose between several possible degrees of power delivery capability, including:

- The USB Type A power protocols listed above,
- USB PD3.0/3.1 – voltages 9/15/20V, current 3A, 5A
- USB PPS (SPR mode) (3.3V – 20V @ 3A in 50mV steps)
- USB PPS (EPR mode) (15V – 48V @ 5A max in 100mV steps)

- Qualcomm QuickCharge (QC) 4/4+/5

(USB-C smartphones are commonly provided with cables with a USB Type A plug on one end and USB-C on the other. The supplied Type A charger will usually only support the Type A protocols listed in §3.8.5 above.)

Manufacturers wishing to incorporate USB-C and power delivery capabilities are referred to the specification documents available from the USB Implementers Forum [here](#).

### 3.8.7. Recessing power sockets

<p><b>SC.9</b> Sockets should where possible be recessed. The recess dimensions should be standardised.</p>	<p>This will provide additional resilience against sideways force on appliance leads, and a degree of additional dust/water protection. However, the enclosure moulding must also permit the plug to fully engage with the socket. Allowance should be made for the size of the overmoulding of the plug</p>
---	--

Specifically, if USB-C sockets are included in SHS products, they should be recessed to reduce sideways force. A rectangular recess approximately 14 x 8mm and 20mm deep is suggested. Appliances for use with SHS powered by USB-C should include an overmoulding that will completely eliminate sideways force when inserted in a recessed SHS USB-C socket. (This approach would also be extremely beneficial for the barrel connectors.)

## 3.9. SHS Extras and Accessories [SX]

To provide the highest possible level of flexibility in the use of the SHS, it is recommended that certain accessories are made available by the manufacturer (presumably at an additional charge):

### 3.9.1. Extension leads

It is very likely that users will want to increase the reach of their SHS, for example to provide lights in another room. It is desirable that a mechanism is provided for this, to avoid the user attempting to do it themselves.

<p><b>SX.1</b> It is recommended that the manufacturer should offer extension leads as standard accessories, to discourage the use of unsuitable products or users' own wire.</p>	<p>These will be of a length and gauge to provide a voltage drop of no more than 500mV at full current.</p>
---	---

They should be supplied accompanied by advice that extension leads should not be daisy-

chained.

### 3.9.2. Selecting Suitable Cable

A table of minimum copper wire cross-sectional area in mm<sup>2</sup> to produce a 500mV voltage drop may be found helpful in this context:

		Cable length in metres									
		1	2	3	4	5	6	7	8	9	10
Current (amps)	1	0.07	0.14	0.21	0.27	0.34	0.41	0.48	0.55	0.62	0.68
	2	0.14	0.27	0.41	0.55	0.68	0.82	0.96	1.09	1.23	1.37
	3	0.21	0.41	0.62	0.82	1.03	1.23	1.44	1.64	1.85	2.05
	3.5	<b>0.24</b>	<b>0.48</b>	<b>0.72</b>	<b>0.96</b>	<b>1.20</b>	<b>1.44</b>	<b>1.68</b>	<b>1.92</b>	<b>2.15</b>	<b>2.39</b>
	4	0.27	0.55	0.82	1.09	1.37	1.64	1.92	2.19	2.46	2.74
	5	0.34	0.68	1.03	1.37	1.71	2.05	2.39	2.74	3.08	3.42
	6	0.41	0.82	1.23	1.64	2.05	2.46	2.87	3.28	3.69	4.10
	7	0.48	0.96	1.44	1.92	2.39	2.87	3.35	3.83	4.31	4.79
	8	<b>0.55</b>	<b>1.09</b>	<b>1.64</b>	<b>2.19</b>	<b>2.74</b>	<b>3.28</b>	<b>3.83</b>	<b>4.38</b>	<b>4.92</b>	<b>5.47</b>
	9	0.62	1.23	1.85	2.46	3.08	3.69	4.31	4.92	5.54	6.16
10	0.68	1.37	2.05	2.74	3.42	4.10	4.79	5.47	6.16	6.84	

For example, a commonly found wire size is 2.5mm<sup>2</sup> (Europe) or 14AWG (N. America). If using this wire to extend the reach of an SHS to an appliance drawing 8amps, the distance should be limited to no more than 4.5metres – and only if the appliance minimum operating voltage limit is 10.0V or below.

### 3.9.3. Adapters for using Low-Power Appliances with High-Current Supplies

As the high-current limit is set at 8amps, the probability of a fault in a low-current appliance causing a fire is considered minimal. There is therefore no technical reason to forbid basic and smart appliances with maximum load currents below 3.5amps having B8/S8 plugs, though this will of course prevent them being plugged into B3.5/S3.5 sockets (even though they would be electrically compatible).

**SX.2** It is recommended that an adapter should be made available by the manufacturers of products that only have B8/S8 connectors, comprising a combination 5525 socket and 3.5mm stereo jack socket, and a short lead to an S8/B8 plug.

This will work for both smart and basic appliances. (This of course will be a custom product.)

It might look like this:

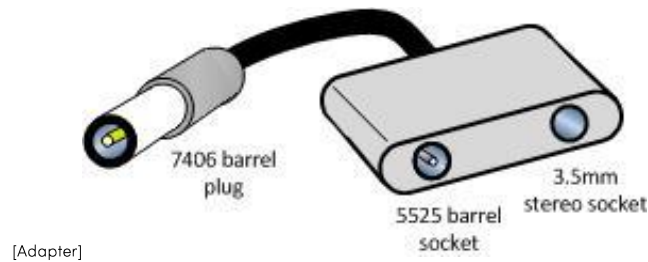

As the 5525 socket is limited to 3.5amps, a second basic 5525 socket could even be added to the adapter, connected in parallel – though if the PAYGo load expired, both appliances might lose power. (At this low power, there is no need to incorporate a fuse.)

Note: If in future higher-power port standards are defined, it is likely to be necessary for adapters enabling low-power devices to be powered by high-power ports to include fuses or cut-outs.

#### 3.9.4. Adapters for different sizes of 5.5mm barrel connector

Both 5525 barrel plugs (5.5mm OD, 2.5mm ID) and 5521 plugs (5.5mm OD, 2.1mm ID) are extremely common on 12V appliances, but it was necessary for the Connect Initiative to standardise on one. The 5525 connector has been chosen. Many appliances with 5521 plugs are unable to plug into this, but are electrically compatible. It is desirable that these appliances are supported.

**SX.3** It is recommended that adapters to allow a 5521 plug to connect to an SHS equipped with 5525 sockets should be included within the list of available accessories.

This will allow both common sizes to be supported.

When supplied, attaching a repeat of the reminder that even if the plug fits (with or without an adapter), it may not be electrically compatible, may be appropriate.

A possible source of adapters may be found at <https://www.aliexpress.com/item/32925703732.html> .



### 3.10. Labelling of SHS Output Ports [SL]

By opening up the interface between the electricity supply and the appliance, we are implicitly encouraging the user to experiment with alternative appliances. It is therefore essential that the user is given clear indication of issues that might cause incompatibility, and that are not immediately visible.

The required equipment labelling should either be incorporated into the plastic moulding of the case or if printed should comply with the test of IEC 60068-2-70.

This information should also be given in the User Manual, but as we all know, these are rarely read. It is therefore necessary that the information is labelled on the equipment itself as well. As the information relates to the output ports, the information should be provided as near the port to which it relates as possible within the constraints of space.

#### 3.10.1. Labelling of SHS Voltage

The voltage of an SHS is a key parameter. Most SHS products today are nominally 12V – but not all.

- |   |  |
|---|--|
| <p>SL.1 Voltage – B3.5/S3.5/B8/S8 sockets – The power output port should be clearly labelled "12VDC" adjacent to the port. The symbol "12V <math>\overline{\text{---}}</math>" (Unicode U+2393) may also be used.</p> | <p>The user needs to know that the output of the SHS is nominally 12VDC, and only appliances with an input voltage including 12VDC should be connected to it. They should not have to consider the permissible actual voltage range represented by this nominal voltage.</p> |
| <p>SL.2 Voltage – equipment with three NMC cells – These should be labelled 11.1VDC (not 12VDC).</p>  | <p>The user needs to be warned that this is not a regular 12VDC port.</p>  |

#### 3.10.2. Labelling of SHS connector polarity

This is fortunately less of an issue than it used to be, but this information should be readily visible, as there are many millions of legacy 12V appliances in the field with the opposite polarity.

- |  |   |
|--|---|
| <p>SL.3 Connector Polarity – The following symbol should be present on the box near the B3.5/S3.5 power socket, and also in the user manual:</p> | <p>The user needs to be able to compare this with a polarity marking on an appliance.</p> |
|--|---|



- |   |                                     |
|---|-------------------------------------|
| <p>SL.4 Connector Polarity – The following symbol</p> | <p>The user needs to be able to</p> |
|---|-------------------------------------|

should be present on the product near the power socket, and also in the user manual:

compare this with a polarity marking on an appliance.

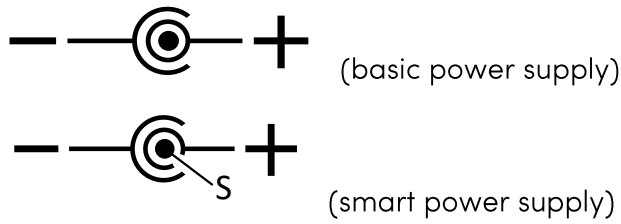

### 3.10.3. Labelling for Two Examples of Current-Limiting Architecture

Labelling will be critical if user expectations are to be managed effectively.

Where the current limit is a total limit for several ports in parallel, it should be labelled as in the following examples:

#### Example 1

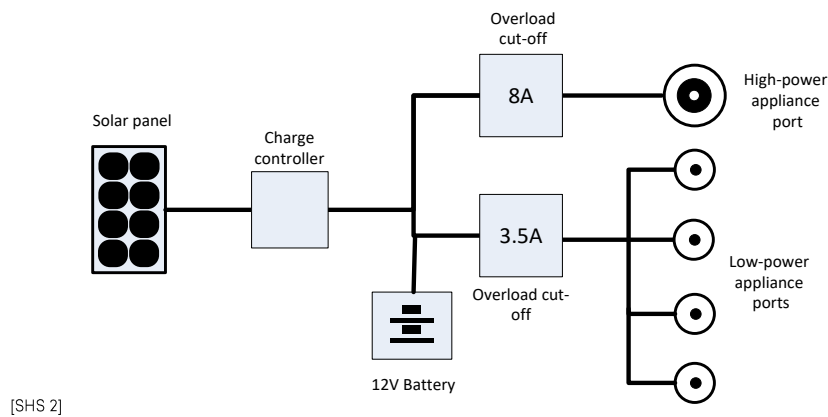

[SHS 2]

This should be labelled as follows:

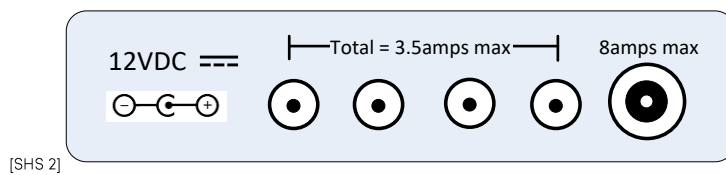

[SHS 2]

Note that in this example, 8amps will still be available on the right-hand socket when the other four are drawing a total of 3.5amps (total equipment load = 11.5amps).

#### Example 2

In this example, the equipment is only capable of delivering 8amps in total:

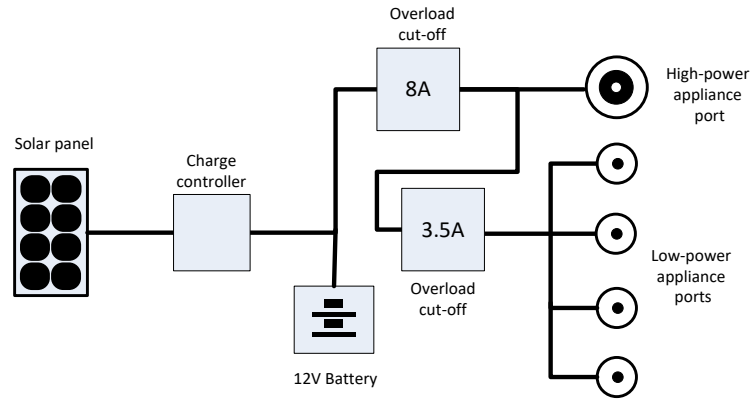

[SHS 2]

Labelling in this case should be as in this example:

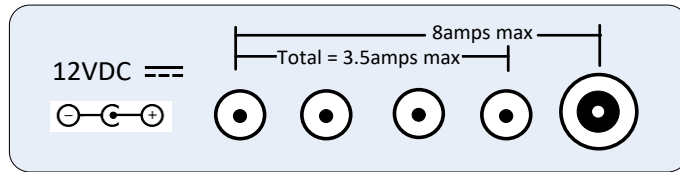

[SHS 2]

- |  |  |
|--|--|
| <p>SL.5 Ports should be labelled with their rated steady-state current capability, according to the criteria above.</p>  | <p>This will help the user to do the necessary current arithmetic to determine whether the SHS has sufficient power</p>  |
| <p>SL.6 If USB Type A sockets are provided, they should have the maximum current labelled (eg "0.5A" or "2.1A"). If a fast charging protocol is supported, text indicating that, or the relevant proprietary symbol should also be included. If the voltage for fast charging exceeds 5V, this should also be indicated, eg "QC3.0: 5V/3A 9V/2A"</p> | <p>Fast charging is widely misunderstood. The wrong fast charging protocol may prevent a smartphone charging at all.</p>   |
| <p>SL.7 If a USB-C socket is provided, information about the capabilities of the socket should be shown next to the socket and in the User Manual. (The correct labelling to be used is still under discussion.)</p>   | <p>All USB-C sockets are not alike – though most people think they are! (The official USB-C specification makes no mention of labelling, despite there being many subsets of USB-C functionality.)</p> |

### 3.11. SHS User Manual Guidelines [SU]

The User Manual should contain all of the information included in the labelling section above, with a written description of the meaning of any symbols used. In addition the following Guidelines should be met:

#### 3.11.1. Support for users with limited mastery of international languages

- SU.1** If you are going to permit users to add their own appliances, local language translations of the User Manual should be provided.
- (Yes, user manuals are usually ignored, but they might not be, if they are readily understood.)
- The User Manual is an essential component of meeting the user's expectations.
- It should not be assumed that the user has mastery of an international language.
- NB: It may be challenging to ensure that these translations deliver this technical information in a meaningful way.

#### 3.11.2. Information about SHS Status Indicators

- SU.2** The meaning of each possible state of each of the status indicators listed under [SI] above should be clearly described. Recommended remedial action to be taken for each exceptional indication should be given – in particular whether advice should be sought from the supplier of the SHS, or the supplier of the appliance.
- There are few things a user finds more maddening than an error indication that gives no insight into the nature of the error, or the possible remedial action to take.
- No supplier wants to spend a long time diagnosing a problem that turns out to be in another supplier's product.

#### 3.11.3. SHS Technical Specification Template

The Technical Specification covers the parameters of immediate concern to the end user. It is a necessary but not sufficient condition to guarantee interoperability.

- SU.3** The published product literature should include a Technical Specification. This should provide basic information necessary for a potential technically qualified user or their advisor to assess the suitability of the product for any
- This sets out the manufacturer's commitment to the performance of their product. The purpose of testing is to ensure that these promises will be kept.

particular situation. This should include at least:

- Nominal output port voltage (12V),
- The maximum total load current,
- The realisable stored energy capacity
- Number of compliant general appliance ports of each type,
- The maximum load current through each port or group of ports,
- The number of non-compliant ports (if any)

An example template for this is provided:

#### Technical Specification – Solar Home System

Operating Temperature:	5°C - 40°C
Relative Humidity:	20% - 85%
Water/dust protection:	Solar panels: IP54 Controller: IP22
Output port voltage:	12VDC nominal, CONNECT AFFILIATES compatible
Total current to output ports:	9.5amps nominal, CONNECT AFFILIATES compatible
Realisable energy storage capacity:	50Watt-hours
General-purpose output ports:	3 * CONNECT AFFILIATES compatible, B3.5, 3amps total 1 * CONNECT AFFILIATES compatible, S8, 7amps max
Special-purpose ports	3 * dimmable lighting ports, 2.5amps total

(Note that environmental limits are outside the scope of this document, but still important.)

#### 3.11.4. Connection of inappropriate load appliances

Unfortunately, there are many millions of DC appliances in the field **with the same connectors** that are **NOT** electrically compatible with Connect Affiliates SHS products. These appliances may be damaged by plugging them into an SHS.

If the specification given in §3.5 above is implemented, it is unlikely that an external connection to an output port will cause damage to the SHS, but it may have undesirable effects on the equipment that is connected.

In particular, it is not possible to predict the effect of an SHS on an external power source, such as a standalone rechargeable battery or lump-in-line/plug-top power supply (which cannot have been tested for compliance with this document).

**SU.4 It is therefore a guideline that the following notice be included in the SHS User Manual:**

The belief that if the plug fits, it should work is very deep-seated, even among engineers

WARNING: There are many appliances that use the same plugs, but that are NOT electrically compatible! *Do not plug any appliance into your SHS*, unless the appliance is labelled "12V", or a voltage range spanning 12V. Attempting to do so may permanently damage your appliance!

Even if 12V is indicated, the polarity may be wrong. If the appliance doesn't work straight away, disconnect immediately.

### 3.11.5. Advice concerning Extension Leads

**SU.5 The published User Manual should include a warning against adding one's own wiring to increase the reach of the system.**

An excessively long or thin extension lead is likely to cause an appliance to malfunction.

The following wording is suggested:

This Solar Home System and any appliances supplied with it are intended to have the appliance(s) plugged directly into the SHS.

If you need to increase the reach of your system, optional extension leads are available. You should acquire the extension lead of the length you require, and not daisy-chain two shorter extension leads – as this may cause your appliance to misbehave.

It is not recommended to add your own wiring to the system, but if you do, it is essential that the wire is sufficiently thick (longer wires need to be thicker).

### 3.11.6. Use of SHS as a battery charger

SU.6 It is recommended that specific instructions are included in the user manual warning against using an SHS to charge a rechargeable battery unless specific measures are taken. Charging a battery is a legitimate and reasonable task for an SHS, but it may be hazardous to the SHS, the battery or to the user if not done correctly.

3.11.7. Warning against injecting power into an output

SU.7 It is recommended that a warning is provided against plugging a mains power supply into an output port of the SHS for any reason at all. This could cause a lithium battery to catch fire, or a lead-acid battery to emit hydrogen.

3.11.8. Advising the user that low-voltage mode is in operation

SU.8 The deep discharge waiver in the remark to [-9-5] Table EE.3 should not apply unless all the guidelines in this document for low-voltage modes are met. No-one reads the manual!

# Appliances

## 4. Connect Affiliates Guidelines for Appliances

It must be expected that an SHS with a common connector will be used to power appliances sourced in the general marketplace. Results may or may not be satisfactory. The Connect Initiative recognises that many users want the flexibility to use their own appliances with a Connect Initiative SHS, so the specifications have been written so as to be compatible with a wide range of 12VDC appliances that already exist in the marketplace.

This section of the Connect Affiliates document specifies those recommendations which if, if an appliance adheres to them, will maximise the probability of (but not guarantee) a satisfactory outcome.

Procedures for testing the compliance of an appliance with these guidelines are given in §7.

### 4.1. Appliance Operating Voltage Range [AV]

It is likely that the voltage of a nominally 12V system will vary by a much greater percentage than would be the case for some higher voltage. Any appliance should be able to accommodate this. It will generally be necessary to provide some stabilisation to maintain functionality over the entire voltage range.

To ensure appliance compatibility, it is assumed that if an appliance functions correctly at the highest possible SHS output voltage and also at the lowest possible output voltage, it will also function correctly at all voltages in between these limits.

It is necessary for its correct function that an appliance has the power it needs to function regardless of voltage. To achieve this, it is desirable that it should present a constant-power characteristic as voltage varies – and hence the maximum current will occur at the minimum voltage. In contrast:

- A constant-current load will have power proportional to voltage: ( $P \propto V$ )
- A constant-resistance load will have power proportional to voltage squared: ( $P \propto V^2$ )

In any of these scenarios, the maximum appliance power consumption will occur when the voltage is highest, and the least when it is lowest.



#### 4.1.1. Appliance Maximum Operating Voltage

It is important that the appliance functions correctly at the maximum permissible operating temperature, and that no component overheating or electrostatic component damage occurs at this voltage.

- AV.1** The appliance should continue to function correctly when supplied with a voltage of 15.0V when under maximum load. This is the maximum voltage specified in §3.2.1 and [-9-5] and [-9-8].

#### 4.1.2. Appliance Minimum Operating Voltage

Note that at the minimum operating voltage, the current drawn by a constant-power device will be at a maximum. It is therefore possible for components to overheat at minimum operating voltage, even if they are cool at the maximum voltage.

- AV.2** The appliance should continue to function correctly when supplied with a voltage of 10.0V when under maximum load. This is 500mV below the voltage specified in §3.2 and [-9-5] and [-9-8], to allow for voltage drop in wiring – see §4.1.4.

#### 4.1.3. Appliance Operating Voltage Range

Providing an operating voltage range gives the user more information, and potentially permits operation with a wider range of supplies. Many products designed for vehicles will operate successfully at both 12V and 24V. Appliances with lower minimum voltage limits are likely to work satisfactorily with SHS products at 11.1V.

- AV.3** If the ratings plate on the appliance or the Technical Specification in the User Manual indicates a wider voltage range, it should be tested over this range. To be consistent with the "Truth in Advertising" requirements.

#### 4.1.4. Allowance for voltage drop in cables

Although [-9-5] and [-9-8] do not require this, it is our guideline that the minimum operating voltage range for appliances should be lower than the minimum output voltage of the SHS.

- AV.4** It is recommended that the minimum operating voltage of an appliance should be lower than the minimum This is because it is likely that users will introduce extension leads or their own wiring, which will contribute an additional voltage loss when current is being drawn.

output voltage of an SHS by 500mV.

#### 4.1.5. Appliances supporting a low-voltage mode

Some critical low-power loads (usually lights) are capable of continuing to operate in low-voltage mode.

**AV.5** An appliance that is intended to continue in operation in 'low-voltage mode' should continue to operate correctly down to a minimum supply voltage of 9.0V.

We define this as the minimum 'low-voltage mode' output voltage.

NB: See the note in §4.5.2 below about the labelling of appliances that will continue to operate in 'low-voltage mode'.

#### 4.1.6. Operating Voltage for LED Lights

LED lights for operation on 12VDC typically comprise four LEDs in series, in series with a resistor and possibly some control electronics. As white LEDs have a forward voltage ( $V_f$ ) of around 3.0V, the light output will fall extremely rapidly as the voltage gets below 12.0V, and unless limited electronically, the current will be excessive at 15.0V. In order for LED lights to meet this spec and continue to provide a similar light output for voltages as low as 10.0V and as high as 15.0V, buck-boost electronics entailing an inductor and additional switching semiconductors may be required.

## 4.2. Appliance Rated Current [AP]

As SHS output port capability is indicated in amps, it is desirable that the power consumption of appliances is similarly quoted.

**AP.1** The power requirement of an appliance should be indicated on the ratings plate and in the User Manual in amps, rather than watts.

This is necessary to support the "current arithmetic" that the user must do when connecting several appliances.

#### 4.2.1. Maximum Current if not given on the Ratings Plate

Where tests refer to the "Rated Current" of the appliance, but for any reason the ratings plate gives power in watts instead, a figure for Rated Current may be found as detailed below.

#### 4.2.2. Current Rating for Electronic Appliances

Appliances that contain electronics are typically constant-power, and as a consequence their load is often expressed on the ratings plate and in the User Manual and Technical Specification in watts. In contrast, the power limits of an SHS output port are expressed in terms of current. Unless the information provided with the appliance includes a maximum load current, it will therefore be necessary for a user doing "current arithmetic" to convert the power rating of the appliance into a current rating.

The current the appliance will need to draw to get the power it requires is determined by the voltage experienced by the electronics within the appliance. This will be lower than the SHS output port voltage by some value, due to the voltage drop in the power lead. It is suggested that 100mV be used for this.

The lowest possible voltage the electronics in the appliance may have to operate on could therefore be 10.5V – (maximum voltage drop in user wiring, 500mV) – (voltage drop in power lead, 100mV) = 9.9V. The guideline is that this voltage is used as follows:

$$\left( \begin{array}{l} \text{Maximum appliance} \\ \text{load current in Amps} \end{array} \right) = \frac{(\text{Power rating of appliance in Watts})}{9.9}$$

**Note:** *This is likely to give a much higher current figure than might be expected – but it does represent the limiting case.*

#### 4.2.3. Current rating for appliances supporting low-voltage mode operation

For electronic appliances supporting low-voltage mode, the maximum current will occur at the minimum voltage. In that case, the rated current should be calculated as:

$$\left( \begin{array}{l} \text{Maximum appliance} \\ \text{load current in Amps} \end{array} \right) = \frac{(\text{Power rating of appliance in Watts})}{9.0}$$

#### 4.2.4. Current Rating for Resistive Appliances

If a resistive load only quotes a power rating, the user/Systems Integrator should assume that this is at 12V. The maximum current for a resistive load will occur in this case at the maximum possible SHS output port voltage (15.0V). Surprisingly, the same formula in §4.2.2 may be used.

#### 4.2.5. Connect Affiliates Standard Current Ratings

The Connect Affiliates standard current ratings are as follows:

**AP.2** Appliances fitted with B3.5 or S3.5 plugs should not have a ratings plate current exceeding 3.5amps. [This is the Connect Affiliates B3.5/S3.5 standard.](#)

- AP.3 Appliances fitted with B8 or S8 plugs should not have a ratings plate current exceeding 8amps. [This is the Connect Affiliates B8/S8 standard.](#)

Appliances fitted with these connectors may have rated currents less than the maximum permitted.

#### 4.2.6. Load Current/Time Profile & Maximum Continuous Load Current

- AP.4 The load current is permitted to exceed the maximum rated current (or the current calculated above), for example when first connected to power, when starting under full load at either its maximum or minimum operating voltage (or at any other time) but the duration should be limited. [The rated current is the maximum current drawn for several seconds or longer. Brief transient currents may exceed this, according to a formula.](#)

Specifically, the load should not cause the overload protection of the supply to be triggered. This means that the current when powered by a stabilised power supply set to the minimum or maximum permissible steady-state voltage should meet one of the following two conditions:

$$i_{load} < (I_{rated} (1 + 4e^{-t/T})) \quad (e1)$$

$$t < 8 * 10^{-5} \text{ secs} \quad (e2)$$

...where the symbols have the following meanings:

- $i_{load}$ : The load current measured at appliance
- $I_{rated}$ : The published rated maximum steady-state load current for the appliance (from the ratings plate or Technical Specification)
- $t$ : The time in seconds since the current exceeded the rated value – ***note that this is not necessarily the time since power was first applied.***
- $T$ : Time-constant in seconds. A guideline value of 0.3secs is given.

If the rated current of the appliance is the same as the rated current of the SHS output port, the following graph shows that this will not trip the overload protection:

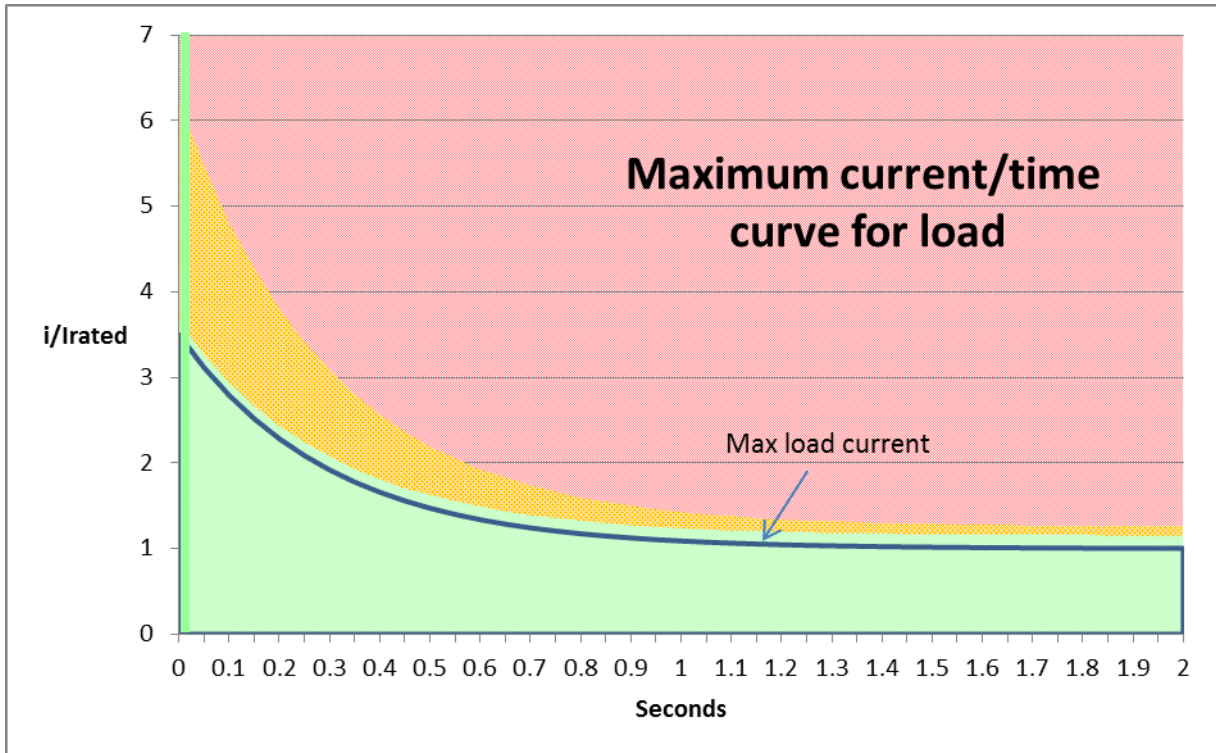

Inrush current2.xlsx

The time is the time since the current first exceeded the peak value printed on the ratings plate. This may not be the time since power was first applied. (For example, a refrigerator with a motor will repeat this curve every time the thermostat closes.)

Although adherence to this curve will ensure that nuisance tripping does not occur if all attached appliances comply, there may also be appliances attached that are not compliant with this document. With this in mind, it will be beneficial for a compliant appliance to wait for an arbitrary delay after power is first applied, before drawing significant current.

### 4.3. Appliances and Galvanic separation [AG]

Galvanic separation is a very poorly understood issue. Since the demise of 'hot-chassis' radios and televisions in the late 1950's, all mains-powered audio-visual equipment and computers have included galvanically isolated power supplies. This is essential not only to ensure safety, but also to prevent earth-loops when two mains-powered devices are connected together by a signal cable. It is now completely taken for granted.

AG.1 It is recommended that product designers should consider the issue of unintended ground loop currents very carefully for all products that include signal ports in addition to the

This may necessitate the inclusion of additional galvanic separation components within the design.

power input port.

12VDC appliances hardly ever include galvanic separation. If the appliance has any kind of external signal interface (audio, VGA, HDMI, USB etc), there will be a low-resistance path between one pole of the power supply (usually the negative) and the signal ground of the external interface.

Fortunately, the lack of galvanic separation is only an issue if:

- The appliances have a signal cable between them
- Both are powered from the same DC supply
- ....and even then, it may not be a problem

It is not an issue for (say) a pedestal fan, a light or a sewing machine – all standalone appliances without external signal ports. It may be a problem for a laptop connected to a monitor, or for a satellite receiver connected to a television.

#### 4.3.1. Current-sharing

The low-resistance path through the appliance isn't usually a problem, but it can provide an alternate path for current to flow, which is unlikely to have been allowed for in the design of the appliance – for example, the printed circuit tracks connection power ground and signal ground may be narrow. In certain circumstances, this current may be large (it could even be larger than the current drawn by either appliance – see below) and this could damage the signal cable or either of the appliances it is connecting.

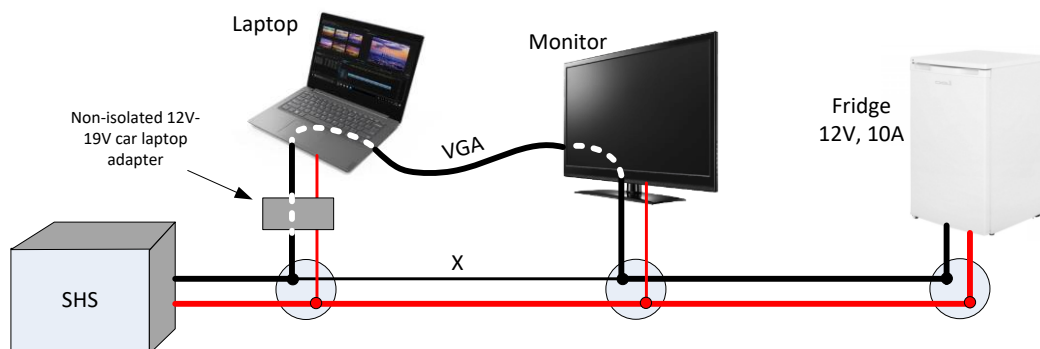

In the figure, if the resistance at X is similar to the resistance of the path through the laptop, VGA cable and monitor, the 10amp fridge current will be shared equally between the supply cable and the printed circuits in the laptop and monitor. In the worst case (if the cable was actually broken at X) all of the current drawn by the fridge and the monitor would flow through the laptop!

In this example, the order in which items are connected is important, if a pulse of fridge startup current through the laptop is to be avoided.

#### 4.3.2. Signal Noise

In addition to damage caused by excessive current, lack of galvanic separation may also generate electrical noise which causes appliances to malfunction or data to be corrupted. The current drawn by an appliance may contain noise components covering a very wide frequency range.

A large current in a signal lead generates a voltage across the milliohms of the resistance of the signal cable, and this voltage is added to the signals being passed across the lead, usually as a combination of voltage offset and broadband noise.

#### 4.3.3. Signalling Protocols and Galvanic separation

The susceptibility of the signal between two appliances to corruption varies with the type of signal:

**Audio** (eg 3.5mm stereo jack) – very sensitive to both noise and voltage offset caused by current-sharing. This will be a problem for an audio amplifier or powered loudspeakers. Some (but by no means all) audio products intended for use in cars, incorporate audio amplifier chips (eg TDA7850) that include a mechanism for cancelling out any voltage offset caused by lack of galvanic separation. Noise issues may be minimised by careful use of differential input amplifiers.

*Note: As this can make 12V audio equipment unusable, a note in the user manual is needed, warning about this.*

**Twisted-pair Ethernet** (RJ-45) – is a fully isolated standard, so galvanic separation will not be a problem (max >100V)

**USB** (any style of connector) – USB only allows data along the same cable as the USB power, to avoid galvanic separation issues. For this reason, separate signal cables should not be used between two items of equipment powered from the same USB source.

**VHF or UHF radio/TV** (RCA or F-type connector) – very susceptible to high-frequency noise, but easily galvanically isolated via a small ferrite ring transformer – but note the outside of the connector should be isolated from the chassis of the equipment.

**SCART and VGA** have separate grounds for each of the unbalanced analogue signals. The noise immunity therefore depends on how the grounds are terminated at each end, but expect disturbance of the video image.

**DVI** may be digital or analogue. DVI-D has balanced high-speed digital pairs, each with its own screen, and should be largely immune from galvanic separation issues. However, there are also unbalanced lower-speed digital data lines used for determining monitor resolution capabilities etc, and these may be mis-read. DVI cables also have a signal ground line and screen – and these may end up carrying significant current.

DVI-A uses the same connector as DVI-D, but is less common. This is equivalent to VGA, and will be prone to video noise issues.

HDMI uses a different connector from DVI-D, but galvanically, it is equivalent.

DisplayPort is fully digital. It may use the same signalling protocol as HDMI and DVI-D, or it may use its own.

For all of these, the presence of a screen connected to earth at both ends, and also in some cases a signal ground, may cause unintended current flows. Cutting the screen and/or signal ground at one end of the cable will solve the unintended current flow, but will make the signal noise much worse.

#### 4.3.4. Designing out Galvanic separation Issues

Insertion of components in the path from the negative supply input to the signal port ground may help in managing the issue by concentrating all the current sharing and noise issues in one place, where electronics can deal with it effectively. This is only a partial solution for when the common mode voltage is likely to be millivolts rather than volts, and of course it must be done at design time – retrofitting later is rarely an option. A low-value resistor is sometimes added for this purpose, or two back-to-back diodes:

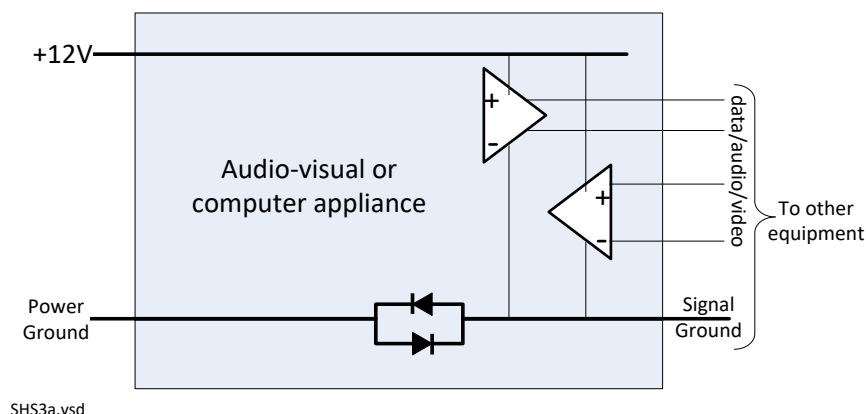

However, don't be tempted to implement low-side power switching, as the signal lead will short an open switch, and turn the power back on. When turned on, the "on" resistance of the switch will also increase the problem.

Analogue signals will benefit from differential (or ideally balanced) signals, but only some connector standards and signalling protocols will permit this.

**AG.2** It is recommended that products that include signal ports in addition to the power input port should include specific measures to eliminate **Televisions and computer monitors may be exempt from this recommendation.**



unintended current flows between power ports and signal ports.

Incorporating a fully isolated power supply using a high-frequency transformer naturally completely addresses the issue. Unfortunately, an isolating switched-mode power supply (SMPS) has a considerably higher component cost and printed circuit real-estate cost than a non-isolating buck/boost converter.

#### **4.4. Connectors for 12VDC Appliances [AC]**

Appliance plugs should be able to mate with any SHS outlet port with which they are electrically compatible. This guideline allows for several connector options for both Basic and Smart Appliances. Connect Affiliates may implement any or all of these on Appliances that connect to an SHS product:

- B3.5 – a basic power plug capable of drawing up to 3.5amps,
- S3.5 – a smart power plug combination capable of drawing up to 3.5amps,
- B8 – a basic power plug capable of drawing up to 8amps,
- S8 – a smart power plug capable of drawing up to 8amps,
- USB Type A

Basic appliances may be plugged into both Basic and Smart outlet ports of the same current rating. The supported combinations are listed in 5.2.5.

Plugs have been selected to align with de facto standard plugs fitted to "grey market" DC appliances, many of which will be electrically compatible with Connect Affiliates SHS products.

AC.1	The power plug should be a free barrel plug on a lead.	Note that this is the opposite sense compared to plug-top or lump-in-line power supplies.
AC.2	Every barrel plug should be selected to mate with the specified reference jack socket (TBD) and when mated to deliver the required mechanical and electrical properties.	It is essential that when mated, the plug and socket function correctly together.
AC.3	Basic appliances should be able to plug into both Basic	When a user upgrades from a Basic to a Smart SHS system, it should not be necessary to replace the

- and Smart supplies. appliances.
- AC.4 A paid-off PAYGo Smart appliance should also be able to plug into a Basic supply, perhaps by means of an adapter Once a PAYGo appliance has been paid off, it should have exactly the same functionality as a Basic appliance.
- AC.5 A detachable lead may have identical connectors on both ends – or very obviously different connectors on the two ends. A lead with different but superficially similar connectors on both ends is confusing to the user.  
(The gender of power leads is in general confused, so cannot be used as a way to prevent compatibility issues with grey market equipment.)
- AC.6 (deleted)

A detachable power lead in IEC terminology is called a "coupler". (A detachable 12V appliance lead coupler is the 12VDC equivalent of the mains couplers defined in IEC 60320.)

- AC.7 A detachable lead should NOT be compatible with IEC60320. A lead with an LVDC plug on one end and an IEC60320 connector on the other end would be a dangerous object.

#### 4.4.1. B3.5 Basic Low-Power Plug

The 5.5mm outside diameter barrel plug has been selected for appliances consuming up to 3.5amps, as this is the most prevalent connector used by Connect Affiliates and the grey market for low-current 12V appliances.

- AC.8 The B3.5 plug should be 5.5mm outside diameter and 2.5mm inside diameter. An adapter will be needed for appliances with 5521 barrel plugs – see §3.9.4.
- The plug should have a barrel length of 12mm. This is the most generally-applicable length of barrel. A long barrel in a short socket isn't a problem, a short one in a long socket is.
- The tuning-fork variant of inner contact is preferred. The tuning fork gives a more consistent contact resistance.

*NB: for this to be a viable policy, it is clearly essential that the Connect Affiliates move away as quickly as possible from using 5.5mm OD barrel connectors for any other purpose (for example, for solar panels).*

AC.9 The polarity of the B3.5 connector should be centre-positive.

This is by far the most popular polarity in the grey market and among Connect Affiliates.

If legacy SHS equipment has 5521 sockets, 5525 appliances may work unreliably. Adapters to solve this are unfortunately not widely available.

#### 4.4.2. S3.5 Low-Power Smart Plug

Provision of smart functionality using the proposed Open PAYGo Link protocol requires an additional third contact on the appliance plug. This is provided by co-moulding a 3.5mm stereo jack plug with the 5521 barrel plug:

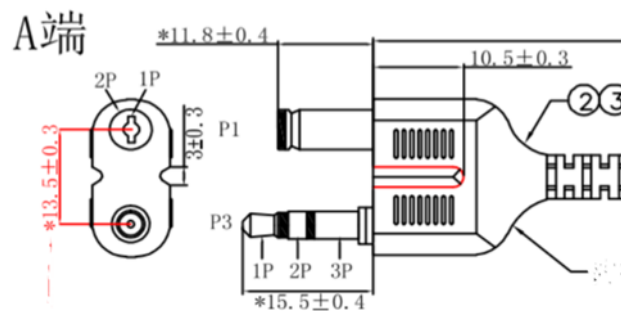

AC.10 The S3.5 smart plug should comprise a B3.5 barrel plug as defined in §4.4.1 and, at a distance of  $13.5 \pm 0.3$ mm from its centre-to-centre, a 3.5mm audio stereo jack plug.

This is the convention adopted by Greenlight Planet.

The connections on the audio jack plug should be:

- 1P - Tip - D+
- 2P - Ring - D-
- 3P - Shank - GND

(NB. See the notes to 3.8.2.1 above.)

The mating face of the S3.5 audio plug should be in the same plane as the face of the barrel plug  $\pm 0.3$ mm.

#### 4.4.3. B8 / S8 High-Power Appliance Plug

Basic and smart appliances drawing maximum currents between 3.5amps and 8amps should be provided with this plug. (Appliances drawing less current may also use this plug, but note that this will limit their use with SHS that only offer B3.5/S3.5 outlets.)

AC.11 The B8/S8 power plug (for loads up to 8amps) should be a 3-pole barrel plug 7.4mm OD, 5.0mm ID with a 0.6mm centre gold pin (colloquially known as a "7406 jack plug").

This has been chosen as the preferred high-current connector for both basic and smart supplies.



(The picture on the left shows the plug module before it has had the lead attached.)

For procurement of the plug, your appliance or lead manufacturer may find it helpful to check out: [https://www.alibaba.com/product-detail/7-4mm-0-6mm-7406-nickel\\_60794722628.html](https://www.alibaba.com/product-detail/7-4mm-0-6mm-7406-nickel_60794722628.html).

AC.12 The polarity of the connector should be outside negative, inner positive. The centre pin should be used for signalling in smart supplies, and not connected in supplies that are not smart-capable.

This is the polarity used by laptops that use this plug. The centre pin will be used for smart signalling, and will be disconnected for basic supplies and loads.

#### 4.4.4. Minimum Cable Size for Fault Resilience

Although in general an overload trip will be triggered in the event of a fault in an appliance, it is possible for such a fault to raise the load current above the rated value but below the value at which the overload trip will be triggered. For example, an appliance designed to take a maximum of 500mA could develop a fault that caused it to draw 3.5amps from a B3.5/S3.5 supply port or 8A from a B8/S8 port.

The existence of adapters as advocated in §3.9.3 means that any appliance within this ecosystem *could* draw 8amps under fault conditions. Leads with integral 5.5mm barrel

connectors should not be required to carry more than 3.5amps in normal operation, but could carry 8amps under fault conditions when powered from an S8/B8 port via an adapter. Significant heating of the connector under these exceptional conditions is acceptable, and of course the voltage drop is likely to be excessive.

AC.13 Regardless of the power the appliance requires in order to operate, the power lead supplied with the appliance should be capable of carrying 8amps continuously, without giving rise to a risk of burns or causing fire, even when wrapped in flammable thermally-insulating material.

Even low-power appliances may be plugged into an S8/B8 output port via an adapter, and may therefore be subject to a current of 8amps under fault conditions. This guideline will ensure safety in the event of an equipment fault. (The risk of a dangerous fault within the appliance itself should already be covered by appliance-specific safety standards.)

#### 4.5. Labelling on appliances [AL]

It is essential that the user is given clear indication of issues that might cause incompatibility, and that are not immediately visible. This information should be given in the User Manual, but as we all know, these are rarely read. It is therefore necessary that the information is labelled on the appliance itself as well.

AL.1 The appliance should have a readily-visible ratings plate or printed ratings box giving basic compatibility information.

This information is still vital, when the User Manual is lost.

##### 4.5.1. Appliance voltage labelling

The nominal operating voltage is probably the most essential piece of information needed to determine where an appliance may and may not be used.

AL.2 The appliance ratings plate should be clearly labelled "12VDC".

The symbol "12V  " (Unicode U+2393) may also be used.

Alternatively, the tested operational voltage limits may be used (eg "9.9–16.8VDC")

If the appliance is also capable of operating from AC over the same

The user should expect to have to match the nominal voltage of the supply and the nominal voltage of the load, but should not have to consider the permissible actual voltage range represented by this nominal voltage.

The appliance may be tested over a wider range than specified here, and that wider range may be reported on the ratings plate.

voltage range, "VAC/DC" may be used.

#### 4.5.2. Low-voltage mode

The introduction in [-9-5] of a low-voltage mode in which when the battery is nearly exhausted a few essential appliances will continue to operate for a while means that the user's expectations of which appliances should and should not be expected to continue to operate must be managed. If this isn't done, users may believe an appliance that ceases to operate in this mode (or the socket into which it is plugged) may be faulty.

- AL.3** An appliance that is intended to continue operating when the SHS is in 'low voltage mode' should have a maximum/minimum operating voltage range indicated, with a minimum operating voltage of 9.0V or less.
- To be consistent with the "Truth in Advertising" requirements.

A special symbol could be defined, to indicate that low-voltage mode is supported.

#### 4.5.3. Appliance peak operating current

The user may need to do "current arithmetic" to determine whether the total load current from several appliances will exceed the capability of the SHS to supply. This is only possible if they are given the information.

- AL.4** All appliances should be clearly labelled with their rated steady-state current requirement, according to the criteria of §5.4 of the main document.
- To give the user the information they will need to do "current arithmetic". This is also a requirement of IEC 60335-1.

#### 4.5.4. Connector polarity labelling

- AL.5** For a B3.5/S3.5 appliance, the following symbol should be present on the appliance's ratings plate, and also in the user manual:
- Although now less common, there are still appliances that have centre-negative polarity.



**Note:** Some thought should be given to how an SHS S3.5 output port is labelled to indicate clearly that the 3.5mm jack socket is not an audio output, but is intended for this very specific application. It should not under any circumstances be possible for a pair of headphones to be plugged into the socket and be damaged.

AL.6 For a B8/S8 appliance, the following symbols should be present on the appliance's ratings plate, and also in the user manual:

This will indicate to a user that a Basic appliance has no connection to the centre pin.

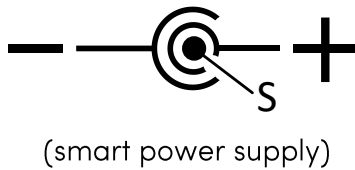
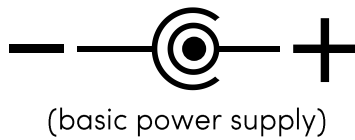

This is a new symbol – I have been unable to find an established one.

AL.7 If the power lead is detachable from the appliance, the symbols above should refer to the connector on the appliance, not the one on the other end of the power lead. (They may need to be modified for different types of connector.)

The user may attempt to use a power lead with a different connector on the other end.

#### 4.5.5. Efficiency Labelling

The energy efficiency of appliances is specifically excluded from this document. So-called “rainbow labelling” of the relative energy efficiency of similar appliances is useful, and is becoming widespread for “white goods” (washing machines, refrigerators, dishwashers, etc) and light bulbs. It encourages manufacturers to increase the energy efficiency of their product, and helps consumers to distinguish between poorer and better products, but unfortunately, it doesn’t warn a user against attempting to power a very large but very

efficient refrigerator from a very small solar system!

#### 4.6. Status Indicators on the appliance [AI]

Most status indicators on an appliance will relate to the function that it performs. However, two status indicators are entirely general:

- |      |   |   |
|------|---|---|
| AI.1 | An appliance that has a mode in which it has power but is not visibly operating (for example, it is in "standby") should have a visible indicator when in this mode to show that it is receiving power. | To differentiate between standby and lack of power.     |
| AI.2 | An appliance that supports 'low voltage mode' should have a status indicator to show that this mode is in effect.   | To show that full functionality should not be expected. |

#### 4.7. Additional Information for the Appliance User Manual [AU]

Of course, most of the information provided in the User Manual for an appliance will be information about how to use the appliance most effectively, and how to take care of it. However, as users will not necessarily be obtaining the appliance from the same supplier as the SHS, some additional warnings are recommended:

##### 4.7.1. Connecting to an inappropriate supply

Unfortunately, there are many millions of DC power supplies in the field **with the same connectors** that are **NOT** electrically compatible with Connect Affiliates SHS products. These power supplies have output voltages ranging from 3VDC up to 30VAC, and the higher voltages could easily damage an appliance.

- |      |   |  |
|------|---|--|
| AU.1 | It is therefore a guideline that the following notice be included in the appliance User Manual: | The belief that if the plug fits, it should work is very deep-seated, even among engineers |
|------|---|--|

WARNING: There are many power supplies that have sockets that may take the plug on your appliance, but that are NOT



electrically compatible! *Do not plug you appliance into a power supply*, unless it is labelled "12VDC". Attempting to do so may permanently damage your appliance!

Even if 12V is indicated, the polarity may be wrong. If the appliance doesn't work straight away, disconnect immediately.

#### 4.7.2. Daisy-chained appliances

Some Connect Affiliates have implemented a daisy-chaining scheme to extend the reach of lighting from an SHS, like this:

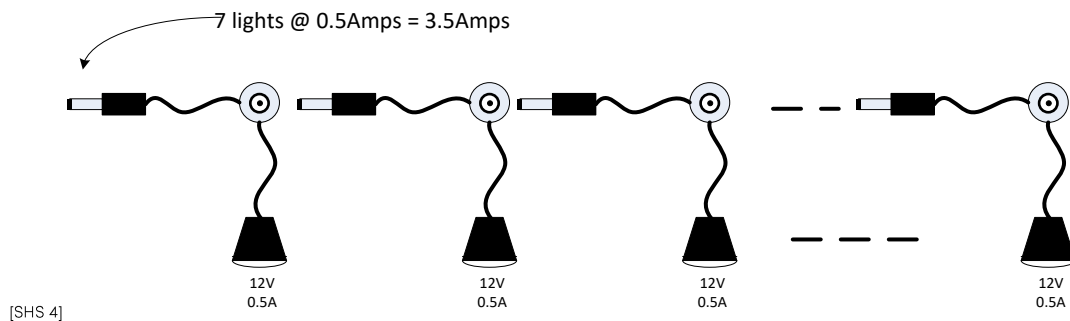

AU.2 The maximum supported number of lights in a daisy-chained should be specified

This will take account of the minimum voltage the last light may have to operate from when the SHS is outputting its minimum possible voltage.

#### 4.7.3. Advising the User how to Avoid Galvanic separation Problems

Rather than require all SHS appliances with external signal ports to include galvanic separation, can we write some simple rules that will ensure that lack of galvanic separation does not cause equipment damage or malfunction?

- Avoid long power lines
- Never power two appliances that have a signal cable between them from the same SHS, one via a short lead and the other via a long lead
- Plug both appliances into the SHS before connecting the signal cable between them.
- Use audio equipment that is specifically designed to go in vehicles

Where an appliance incorporates connectors for purposes other than solely for the delivery of power (ie digital communications, audio, video, radio aeriels etc), and if

specific measures have not been taken within the product to avoid galvanic separation problems, the User Manual should contain advice about the potential issues.

- AU.3** The following wording is suggested for the user manual for any appliance equipped with signal ports There is almost no possibility of explaining this issue to an end user (and even to a distributor or wholesaler, it's very doubtful).

WARNING: Unreliable performance may be experienced when connecting a signal cable between this equipment and another that is powered from the same SHS.

#### 4.7.4. Appliance Technical Specification Template

The Technical Specification covers the parameters of immediate concern to the end user. It is a necessary but not sufficient condition to guarantee interoperability.

- AU.4** The published product literature should include a Technical Specification. This should provide basic information necessary for a potential technically qualified user or their advisor to assess the suitability of the product for any particular situation. This sets out the manufacturer's commitment concerning the performance of their product. The purpose of testing is to ensure that these promises will be kept.

An example template for this is provided:

#### Technical Specification – 12VDC Appliance

Ambient Operating Temperature Range:	0°C - 40°C
Relative Humidity:	20% - 85%
Water/dust protection:	IP22
Operating voltage:	12VDC nominal, CONNECT AFFILIATES standard
Maximum load current:	2.0amps nominal, CONNECT AFFILIATES standard

Input lead connector:	5.5/2.5mm barrel connector plug, centre positive
Energy requirement:	15 Watt-hours per hour of use

#### 4.7.4.1. Energy Consumption and the Technical Specification

Energy consumption is specifically excluded from the scope of this document, but it remains an extremely important part of the task of the Systems Integrator to take account of it, and ensure that run times of appliances are reasonable.

The energy requirement specification will depend on the type of appliance – for example a computer printer might say "1 watt-hour per page printed", a mobile phone might say "7 watt-hours per battery charge from flat".

This document describes additional requirements that the end user should not have to worry about (and are optional for inclusion in the Technical Specification), but that have the potential to cause problems in practice – for example, inrush current, or galvanic separation.

#### Option:

It would be extremely beneficial for the Appliance Technical Specification to include two additional lines:

Required additional battery capacity for typical use:	50 Wh
Required additional solar panel size for typical use:	0.5m <sup>2</sup> (This could also be expressed as Wp, kWh/day etc.)

The "*Required additional battery capacity for typical use*" figure is the amount the battery size would need to be increased by, to ensure that addition of this appliance to the household did not increase the probability of the battery becoming exhausted before the sun next shines. It therefore includes not only the "Energy requirement" listed above, but also takes account of the likely usage during the day, and whether that usage is likely to be when the sun is shining. The value is dependent on human usage patterns, and consequently cannot be calculated – it has to be based on experience of similar installations.

The same comment applies to "*Required additional solar panel size for typical use*". This will include the increase in solar panel capacity required to charge the increased battery size, plus any additional capacity needed to operate the appliance when the sun is shining.

**Note:** *These figures will inevitably be highly subjective – but they do represent what the user needs to know.*

These issues will be covered in detail in a future document on product energy requirements.

# Product Testing

## 5. Testing – General Recommendations [T]

### 5.1. Testing Environment

It is naturally essential that Connect Affiliates' products are reliable and dependable in the field. Environmental conditions may have significant impact on the ability of an appliance to perform its intended functions. This should be taken into account wherever possible. Many are shipped to environments that in electronic terms are considered extreme – not only in terms of ambient temperature and humidity, but having airborne dust or salt, insect ingress and rodent damage.

- |   |  |
|---|--|
| <p>T.1     <b>It is recommended that before product design and packaging are finalised, prototypes should be tested in the most extreme environments they are likely to encounter in normal use in the field.</b></p> | <p>Testing in a clean air-conditioned laboratory will not show up all the weaknesses in the product!</p> |
|---|--|

Testing of prototypes in the lab in an environmental test chamber is acknowledged to be expensive, time-consuming, and awkward. Before product designs and packaging are finalised, product prototypes should be put through their paces and tested in the most extreme conditions they are likely to experience in normal use in the markets to which they will be shipped. The easiest way to achieve this is to have the prototypes evaluated and tested at the limits of their technical specification by suitably qualified people located in those extreme environments.

Some of these tests for environmental integrity are described in the standards listed in the Appendix.

### 5.2. Testing to the Technical Specification

The product's Technical Specification published in advertising material and the User Manual represents the manufacturer's promise of what the product can do. Each published parameter should be achievable by every product shipped, and unless there are stated caveats, each parameter should be achievable independent of the value of any other published parameter.

- |  |   |
|--|---|
| <p>T.2     <b>It is recommended that testers identify the most challenging</b></p> | <p>Most product performance testing can be a type-test, but a really critical parameter may need 100%</p> |
|--|---|

electrical conditions consistent with the published Technical Specification, and products are tested to confirm that they achieve their stated performance under these conditions.

testing.

Exactly what the most challenging conditions are will depend on the product, but it is incumbent on the product designer to identify these at design time, if shipping unsuitable or unreliable products to the field is to be avoided.

### 5.3. Testing of connectors

The proposed procedures for the testing of connectors to ensure that they will not cause issues in the field are given in Appendix III (§10).

It is anticipated that standard reference connectors will be selected, that have been found to be satisfactory with the majority of equipment in the marketplace. Initially, it is proposed that each of the Connect Affiliates is asked to provide some samples for testing.

It is proposed that a testing service is set up, which will be able to validate a particular connector for compliance.

T.3 It is recommended that manufacturers have connectors that they plan to incorporate into their products validated by a testing service for performance with a standard reference connector.

This is the only way to ensure that any combination of Connect Affiliates products will work together. Note that there is very wide variation in dimensions and materials between nominally compatible connectors.

This approach is necessary as there are no recognised standards documents including mechanical tolerances that we have been able to find for the chosen 5525 connector.

## 6. Electrical Test Procedures for Solar Home System Output Ports

The objective for testing is to identify and anticipate issues that are going to arise in the field, before they do. Correcting design weakness at the production-prototype stage may be painful, but it is much less damaging and expensive than later.

When changes of design or component supplier occur, judgement is required concerning the extent of retesting that is necessary.

This section describes tests the product designer or others may use to confirm that an SHS complies with the guidelines describe above.

#### 6.1.1. SHS Output Voltage Test Procedures

Equipment required:

- Constant-current electronic loads, fixed resistors (air-or water-cooled if necessary) or rheostats sufficient to load all output ports simultaneously (only one required for a number of ports connected in parallel)  
(a suitable electronic load is <https://www.bkprecision.com/products/dc-electronic-loads/8540-150-w-dc-electronic-load.html> )
- Voltage monitor  
(a suitable product is <https://www.lascarelectronics.com/easylog-el-usb-3> ).
- Solar panel simulator or lab power supply

##### 6.1.1.1. Voltage Test Procedures – General

Generally, the cell voltage is higher at high temperature and lower at low temperature. This means that upper voltage limits of battery supplies should where possible be tested at the highest rated operating temperature (for example whilst fast-charging at close to 100% capacity at the maximum specified ambient temperature). Similarly, the lower voltage limit should be measured when nearly fully discharged at the lowest specified ambient temperature.

The internal resistance causes the battery terminal voltage to change depending on the total load current or charging current. It generally increases with battery age or number of discharge cycles, and may be used as an approximate proxy for the good health of the battery.

SHS terminal voltages will generally be tested with new batteries, when the internal resistance is at a minimum. An additional allowance should be made for increased internal resistance, since it is not sufficient to only deliver compatibility when the SHS is new. Reliable appliance operation should be delivered consistently until the SHS indicates to the user that the battery is no longer functional (and it is therefore a guideline that there should explicitly be such an indication).

A battery simulator (as specified by [-9-5] Annex DD.4.1.2) may save time charging and discharging batteries for tests, but it may only be used provided that all of the characteristics of the battery it is replacing that are listed above are accurately known and

manufacturing worst-case tolerances can be reliably identified.

#### 6.1.1.2. Steady State Upper Voltage Limit [SV.1]

After a unit with a discharged battery achieves thermal equilibrium at the highest specified ambient temperature for the product, the supply is connected to a solar panel simulator or lab power supply delivering the highest power that is possible with the supplied solar panels. The output ports are unloaded. The output voltage is monitored as the battery is charged with the ambient temperature maintained at the specified highest value (battery temperature is likely to rise above this). The maximum recorded voltage during the charging process is the maximum supply voltage for the port

#### 6.1.1.3. Steady State Lower Voltage Limit [SV.2]

Ideally after temperature equalisation at the lowest specified ambient temperature for the product, each port of the SHS is connected to a constant-current load with the current set to the published maximum rated current of the port.

If several output ports are specified with individual current limits, each port should be loaded to that limit (see §3.4). Ports may be loaded using rheostats, provided the current is adjusted to the rated value before measurement is taken.

If several ports are connected in parallel and the total current is specified, one port may be loaded with that total current. (Rating a port on the basis of power is deprecated, but if a port has a rated power rather than a rated current, a constant power load set to the rated power should be used.)

If the product has special-purpose ports that are excluded from the scope of this document (for example PWM lighting ports), these should also be loaded to the maximum permitted.

There is no external (eg solar panel) power input. At each port in turn, the voltage is monitored as the battery discharges until the system shuts down indicating a fully-discharged battery. The voltage just before this occurs is the minimum supply voltage for this port. If a low-voltage mode is supported, the applicable end-point is when the low-voltage indicator indicates that low-voltage mode is active, or when low-priority output ports turn off.

(The battery will of course need to be partially re-charged before testing the next port, unless several voltage monitors are available to measure all ports simultaneously.)

NB This procedure and the next differ from that specified in [-9-5] §EE.4.2.6. In particular, to confirm the "truth in advertising" claim directly:



- A constant current or constant power load at the advertised rated value is used in preference to a resistor, unless the resistor is a rheostat adjusted to the correct current.
- All other output ports are fully loaded to their rated current/power limit
- Rated values are used in preference to overload protection test currents, as these represent the user's expectation.
- §§EE.4.2.6(f) onwards are omitted (since they refer to appliances)

#### 6.1.1.4. Low-voltage Mode – Indication [SV.3]

If a low-voltage mode is supported, this should be indicated either audibly or visibly when it is in effect. Test – by visual inspection.

#### 6.1.1.5. Low-voltage Mode – Minimum Voltage [SV.4]

The unit should be loaded with the maximum current supported in low-voltage mode using the procedure described in §6.1.1.3, and the voltage recorded as it falls. The voltage just before cut-off should be no less than 9.0V.

#### 6.1.1.6. Exceptional Overvoltage Upper Limit – Battery Disconnect Test [SV.5]

Where applicable, the tests specified in [-9-5] Annex DD §4.3 should pass.

#### 6.1.1.7. Testing transient response [SV.6]

(This test is only needed if there is a DC-DC converter or voltage stabiliser between the battery and an output.)

Transient voltages occur in response to sudden changes in current. These may be driven by the supply taking a finite time to respond to a change in load current, or by a sudden injection of reverse current from a load. Transient voltages may cause product damage, or may cause appliances connected in parallel to operate incorrectly.

A test is needed to ensure that no load line characteristic of an appliance (or combination of appliances) could cause instability of the current limiting of the supply. In the meantime, the tests defined in the USB specification and reproduced in [-9-5] Annex EE.4.3 may be used, suitably adjusted for nominal voltage.

### 6.1.2. Testing Output Current [SP,SO]

Testing steady-state values [SP] is undertaken as part of testing for overload conditions [SO].

A programmable electronic load should be used to confirm correct operation of the overload protection.

A possible programmable electronic load might be the Siglent SDL1020X-E, or the BK Precision 8601.

#### 6.1.2.1. Overcurrent tripping [SO.1],[SO.3]

The load is then programmed to successively provide limiting loads as defined in §3.4.2.3(a) or §3.4.2.4(c), and it is confirmed that overload tripping occurs every time. It may be desirable to automate the manual overload trip reset to facilitate the large number of tests necessary to validate the curves defined above.

#### 6.1.2.2. Inrush current non-tripping [SO.2]

The load is programmed to successively provide limiting loads as defined in §3.4.2.3 (b) or §3.4.2.4(d), and it is confirmed that overload tripping does not occur.

#### 6.1.2.3. Output port sequencing [SO.4]

This may be established by observation, or more rigorously with a multi-channel storage oscilloscope.

### 6.1.3. Testing Outputs for electrical challenges [SM]

These tests confirm that the SHS will survive if the user attempts various common experiments.

#### 6.1.3.1. Reverse-Current Protection – Test Procedure [SM.1]

The SHS is turned on so that the output is energised before the lab power supply is connected.

A voltage of 30VDC should be applied from a lab power supply through an ammeter and a series resistor of 10k $\Omega$  to each output port in turn, and a check made that a steady-state current of no more than a 100 $\mu$ A flows (alternatively, a voltmeter may be used to check that the voltage across the resistor is no greater than 1V).

The experiment is repeated with the SHS is turned off. Again, a current of no greater than 100 $\mu$ A should flow, as indicated by the ammeter or the voltage across the series resistor.

The experiments should be repeated for each port or group of parallel ports.

#### 6.1.3.2. Reverse-Polarity Connection – Test Procedure [SM.2]

1. The SHS is turned off. A lab power supply is set to 30V and current-limited to the rated current of the port. It is connected to the SHS output with the positive supply to the negative terminal of the SHS output and the negative supply to the positive terminal of the SHS output. The terminal voltage is measured and confirmed to be of magnitude 1.0V or less.
2. A visual inspection is undertaken to ensure that a protective fuse or fusible link is built into the product between the internal electronics and the positive output terminal. Assuming it is, a lab power supply capable of delivering a current of at least four times the rated current of the port at a few volts is momentarily connected with + to the -ve output and - to the positive, and a check made that the internal fuse blows, and disconnects all internal electronics. ***(NB. This is a destructive test.)***

If several outputs or groups of outputs have protective devices, the experiment should be repeated for each.

#### 6.1.3.3. Mis-wiring tests

[-9-5] describes several tests for protection against mis-wiring, but these only apply to ports that are deemed “general-purpose”.

As Connect Initiative SHS output ports are deemed general-purpose, the condition of [-9-5] Annex DD.4.1.4(a)ii should always apply – the output port should be treated as though anything may be plugged into it, and subjected to the miswiring protection tests specified therein.

#### 6.1.4. Testing of Status Indicators [SI]

The indicators described in SI.1 should all be present (established by inspection).

## 7. Electrical Test Procedures for Appliances

In general, the provisions of [-9-5] Annex FF are applicable, with the exception of runtime calculations and energy efficiency. The principal difference is that appliances for use with Connect Affiliates’ standard Solar Home Systems need to be capable of operating

correctly over the entire supply voltage range, since the appliance should be capable of operating correctly both when the SHS battery is new, and later in its life when the internal resistance has increased. It is also desirable that they operate correctly with any applicable voltage drop in cabling.

#### 7.1.1. Setting the most demanding conditions for appliances

For the purposes of this document, only the most demanding conditions need to be tested. If the most demanding conditions have been correctly identified and the appliance passes under these circumstances, it may be assumed that less challenging conditions will be fine.

Where mechanical loading of motors or solenoids is involved, the maximum permissible mechanical load should be applied (a brake with calibrated torque may be required). The brake should be applied before the motor/solenoid starts moving, if this could occur in practice.

Where sound output and/or screen brightness are relevant and adjustable, they should be turned up to the highest level.

If an appliance needs an external electrical connection in order to meet the most demanding condition (for example, an amplifier may need an audio signal, a battery charger may need a flat battery, an inverter may need a limiting load), this should be supplied. (The tests should also pass with this input absent.)

For refrigeration equipment, the thermostat should be set to the coldest setting and heating equipment to the hottest.

For other equipment, the most demanding condition should be whatever condition causes the steady-state current drawn from the supply to be a maximum.

#### 7.1.1. Voltage Testing – General Considerations

The appliance under test is to be powered by a stabilised lab power supply. For each test, all functions of the appliance should be tested under the most demanding conditions as defined in §5.1.

During the exercising of the functions of the appliance, the load current should be monitored to confirm that the load current does not exceed that stated on the ratings plate.

If a range of operating voltages is not given on the ratings plate, the maximum test voltage should be the maximum SHS output voltage defined in §3.2.1 and §4.1.1. The minimum operating voltage should be that defined in §4.1.2

If an operating voltage range is given, and the limits are narrower than these, the appliance is incompatible with the Connect Initiative, as it will not operate properly under all circumstances.

#### 7.1.2. Minimum operating voltage test

This test should be conducted with all components in thermal equilibrium at the minimum permitted ambient temperature.

The appliance under test should be powered by a stabilised lab power supply set to the minimum permissible voltage, with current limiting set at 150% of the current given on the appliance's ratings plate.

The appliance should be put through its paces and made to perform all its normal functions to their specified limits, including that state which causes the current to be the highest it can be at this voltage. It should perform all of these functions correctly. Where possible, this test should be done after achieving thermal equilibrium unpowered at the lowest supported ambient temperature, and sufficiently quickly to avoid any mitigating effect of component self-heating.

#### 7.1.3. Maximum operating voltage test

The appliance under test is to be powered by a stabilised lab power supply set to the maximum voltage.

With the supply set to the maximum permissible voltage, the appliance is put into that state which causes the current to be the highest it can be at this voltage (and if possible at the highest supported ambient temperature and the test run until thermal equilibrium is reached). At this point, the appliance should be put through its paces, and made to perform all its normal functions to their specified limits. (Exactly what these are will differ between appliances.) It should perform all these functions correctly.

As the principal weakness is likely to be overheating, this test should be conducted at the maximum permitted ambient operating temperature, and the equipment should be operated for sufficient time for thermal equilibrium to be achieved.

#### 7.1.4. Testing barrel plug dimensions

See §5.3 above.

#### 7.1.5. Checking barrel plug polarity

Check by inspection of the ratings plate, or the ratings plate of any mains power supply supplied with the appliance. Polarity cannot be checked by experiment without risk to the appliance. If the labelling below is omitted (and is also omitted from the user manual and any mains power supply supplied with the appliance), proceed as follows:

Using a socket similar to that on an SHS, connect the appliance to a lab power supply current-limited to the current given on the ratings plate, with the centre-pin positive. Turn on and quickly check for the supply voltage falling or lack of appliance functionality. If the appliance doesn't appear to function, turn off immediately, and try the opposite polarity. (Even doing this, there is a possibility of damaging the appliance.)

#### 7.1.6. Appliances supplied with/without a power coupler

If the appliance is supplied with a detachable power lead, all tests should be done with the power lead attached to the appliance.

Load appliances that are supplied without a free plug to connect them to a supply (for example, products supplied with a fixed socket on the load and a lump-on-the-wall power adapter) may also be tested for compliance with this document.

In this case, load testing should be undertaken with a power coupler of length 1.5metres and sufficient current-carrying capacity (as defined in §3.9.2) provided by the tester with a suitable connector on each end, the whole being treated as a single unit as though the coupler were provided with the appliance.

#### 7.1.7. Output variation between highest and lowest operating voltages

For lights, the lumen output should differ by no more than 2:1 between the highest and lowest supply voltages.

For fans, the speed should differ by no more than 2:1 between the highest and lowest supply voltages.

For refrigeration equipment, there should be no difference between the equilibrium temperature at the highest and lowest supply voltage (though the time to reach it may change).

For other types of appliances, other requirements may apply.

The process for taking these measurements is outside the scope of this document.

### 7.1.8. Non-Operating Voltage Tests

The appliance may be exposed to voltages outside the supported operational voltage range, and these should not cause permanent damage. Three types of non-operating voltage are identified.

#### 7.1.8.1. High Voltage Electrostatic Breakdown Test

The test of [-9-5] Annex FF.8.6(a) may be applied. If the appliance does not have an on/off switch, the effect may be simulated by plugging and unplugging the appliance from the supply.

The following tests check situations that should not arise unless users install their own wiring, and are therefore not mandatory. (They are not included in [-9-5] or [-9-8].)

#### 7.1.8.2. Reverse Polarity Test

As the possibility of the user inserting their own wiring is being considered, the possibility of polarity reversal exists. It is very desirable that the appliance should survive this.

**NOTE THAT THIS TEST MAY PERMANENTLY DAMAGE THE APPLIANCE – so it should be done after other tests.**

For this test, set a lab power supply to the highest permitted output voltage, and limit the current to the rated current for the port. Monitor the current and voltage as the appliance is connected with polarity reversed. (Note that it may be necessary to cut the appliance power cord to achieve this.) Leave the appliance in this condition for five minutes, or until smoke or fumes are observed.

If smoke or fumes are observed or both current and voltage remain high after 5 minutes, terminate the test and deem it to have failed. If the voltage is below 1V or the current is below 10mA, and the appliance operates normally after the test, the test is deemed to have passed.

#### 7.1.8.3. Motor Stall Test

**NOTE THAT THIS TEST MAY PERMANENTLY DAMAGE THE APPLIANCE – so it should be done last.**

For an appliance with a user-accessible motor (for example a pedestal fan) whilst unpowered, restrain the motor by any suitable method so that it cannot rotate. (This simulates the situation in which the motor bearings are clogged by dust or lack of lubrication.)

Connect a lab power supply with the voltage set to zero and current limited to the rated current of the appliance + 20%. Turn the voltage up slowly until either the current reaches current-limit or the maximum permitted port voltage is reached. Leave the appliance in this condition for 10minutes or until smoke or fumes are observed or the current drops

suddenly. Allow the appliance to cool down. If it then functions normally, the test is deemed to have passed.

#### 7.1.8.4. Low Voltage Digital Startup Test

Appliances that include digital electronics need to start up cleanly. For many products, this doesn't occur when the voltage rises slowly (for example when an exhausted battery is charged by a solar panel).

Connect a lab power supply with the voltage set to zero and current limited to the rated port current. Turn the voltage up slowly over at least 20seconds until the minimum permitted port voltage is reached. Confirm that the appliance functions normally.

#### 7.1.9. Testing appliance current

A stabilised lab power supply with a current capability at least four times the rated current of the appliance is set to the maximum permitted steady-state output voltage of an SHS. Across its terminals is connected a low-ESR electrolytic capacitor of value approximately 470 $\mu$ F (S3.5/B3.5 port) or 1000 $\mu$ F (S8/B8 port).

A data-logging DC current probe is used to record the current at least every 100 $\mu$ S as the appliance is turned on and put through its paces executing all the functions it is capable of. This should include the most demanding conditions (see §5.2).

The procedure is then repeated with the stabilised lab power supply set to the minimum permitted steady-state output voltage of the SHS.

Suitable equipment for performing the current logging function might be the Hioki CT6711 DC Current Probe ([https://www.hioki.com/global/products/current-probes/wide-band/id\\_6732](https://www.hioki.com/global/products/current-probes/wide-band/id_6732)) connected to the MR8880 Memory HiCorder ([https://www.hioki.com/global/products/data-acquisition/daq-maintenance/id\\_5776](https://www.hioki.com/global/products/data-acquisition/daq-maintenance/id_5776))

The data log is dumped to an Excel file which is analysed to determine whether it complies with the equations above.



## 8. Appendix I – Battery Voltage and Output Terminal Voltage

Most SHS products deliver power at a voltage determined by battery chemistry, and do not have a DC/DC converter or stabiliser on the output. The battery terminal voltage at any time is determined by (a) battery chemistry, (b) battery State-of-Charge (SoC), (c) current direction and magnitude, and (d) ambient temperature.

The relationship between battery voltage and these various influencing factors is generally a curve which may be found in the battery manufacturer's data sheets. Fortunately, each of these curves is monotonic, so the shape of the curve does not need to be considered, provided that the two extremes are within permissible limits.

Although the voltage is related to the state-of-charge of the battery, SoC can only be determined from voltage if all the other influencing factors are taken into account.

Depending on how the SHS is constructed, the maximum output voltage may exceed the battery terminal voltage during battery charging and with low load currents. However, it will be more usual for the output voltage to be lower than the battery terminal voltage by an amount that is a function of the load current at this port and the load current at other ports on the SHS

Verasol provides a very useful guide to batteries – VeraSol technical note 30 (<https://verasol.org/publications/lithium-ion-batteries-part-i-genupdate>).

### 8.1.1.1. Lead-Acid Cell Voltage Range

The most popular lead-acid battery type for SHS appears to be AGM (Absorbent Glass Mat). This has a maximum voltage on charge of 2.40V/cell at 25°C (also specified in [-9-5 Table K.2). The minimum cell voltage is specified in [-9-5] Table L.1 as 1.82V/cell. **The lower voltage should be measured at zero current, and the upper while being charged.**

All nominal 12V lead-acid batteries have six cells, so the possible voltage range is 10.92V – 14.4V.

The internal resistance of a lead-acid battery is not well defined, but typically will increase with the number of charge/discharge cycles. A typical value for a small battery as found in an SHS might be 12mΩ when new, rising to perhaps 30mΩ towards the end of life. In order to specify an output port voltage, a value for the maximum voltage difference between the battery cell voltage (measured at zero current) and the output port voltage

at maximum current should be defined. A value of 420mV is proposed, since this brings the minimum output port voltage to 10.5V in line with [-9-5] Table EE.3.

#### 8.1.1.2. Lithium Battery Cell Voltage Range

According to Battery University (see [here](#)), four types of lithium battery are found in electrical products:

- Lithium Manganese Oxide ( $\text{LiMn}_2\text{O}_4$ ) – LMO: 3.70V (3.80V) nominal; typical operating range 3.0–4.2V/cell
- Lithium Nickel Manganese Cobalt Oxide ( $\text{LiNiMnCoO}_2$ ) – NMC: 3.60V, 3.70V nominal; typical operating range 3.0–4.2V/cell, or higher
- Lithium Nickel Cobalt Aluminium Oxide ( $\text{LiNiCoAlO}_2$ ) – NCA: 3.60V nominal; typical operating range 3.0–4.2V/cell
- Lithium Iron Phosphate ( $\text{LiFePO}_4$ ) – LFP: 3.20, 3.30V nominal; typical operating range 2.5–3.65V/cell

It is thought that all existing Verasol-certified SHS using lithium batteries employ 4-cell Lithium Iron Phosphate batteries. The voltage limits for these batteries specified in [-9-5] are 2.45V – 3.6V per cell (Tables L.1 and K.2 respectively) or 9.8V – 14.4V overall. **The lower voltage should be measured at zero current, and the upper while being charged.** The minimum voltage specified is incompatible with the output port limits in [-9-5] Table EE.3. The guideline cutoff voltage is 2.73V. (The discharge curve is very steep at this point, so little energy is lost by not going lower.)

The internal resistance may vary from 10m $\Omega$  or less for a new high-current 18650 cell to 70m $\Omega$  for a lower-current cell towards the end of its life. Protection electronics may add a further 50m $\Omega$ .

Note: For the specified voltage range in [-9-5] to be achievable with 4-cell  $\text{LiFePO}_4$  batteries and a 420mV maximum voltage drop, the minimum cell voltage defined in [-9-5] Table L.1 should be 2.73V (not 2.45/2.50V as quoted).

The temperature coefficient of lithium cells is approximately +1.0mV/cell/ $^{\circ}\text{C}$ , so a 4-cell battery may be expected to display an open-circuit voltage change over an operational temperature range of 5 $^{\circ}\text{C}$  – 45 $^{\circ}\text{C}$  of 160mV.

#### 8.1.1.3. Output Port Voltage Model

An SHS without voltage conversion/stabilisation may be simplified to the following:

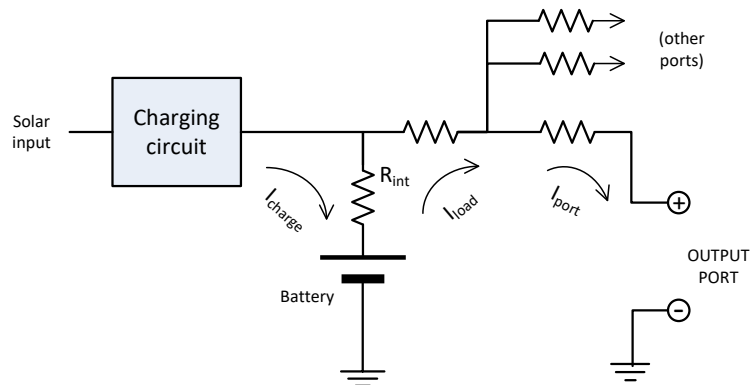

The resistances shown in the model are typically not discrete resistors, but parasitic values of other components, printed circuit tracks, etc. The values will be in milliohms. The values are not well defined and may vary with other conditions. However, they have a significant impact on the output port voltage when current is flowing.

## 9. Appendix II – International Standards applicable to SHS systems

In addition to [-9-5] and [-9-8], the following standards may relate to products covered by this document and could support improved quality, safety, durability, and performance.

IEC 60050 – The International Electrotechnical Vocabulary (IEV). This is publicly available online at <https://www.electropedia.org/> .

Where a technical term is used in this document, and it is not (re-)defined in Section 3, it is deemed to have the meaning defined in the IEV.

IEC 60068-2-5:2018 RLV (Redline version) Environmental testing – Part 2-5: Tests – Test S: Simulated solar radiation at ground level and guidance for solar radiation testing and weathering

Test specifically for wiring and connectors exposed to sunlight.

IEC 60068-2-10:2005+AMD1:2018 CSV (Consolidated version) Environmental testing – Part 2-10: Tests – Test J and guidance: Mould growth

This may be important in some circumstances – most likely where impregnated paper or card is used as an insulating material

IEC 60068-2-21:2006 – Environmental testing – Part 2-21: Tests – Test U: Robustness of terminations and integral mounting devices

Mechanical testing of connectors

IEC 60068-2-30:2005 – Environmental testing – Part 2-30: Tests – Test Db: Damp heat, cyclic (12 h + 12 h cycle)

Humidity testing

IEC 60068-2-38:2021 RLV (Redline version) Environmental testing – Part 2-38: Tests – Test Z/AD: Composite temperature/humidity cyclic test

Humidity/corrosion testing – alternative

IEC 60068-2-43:2003 – Environmental testing – Part 2-43: Tests – Test Kd: Hydrogen sulphide test for contacts and

Corrosion testing for silver contacts

connections

IEC 60068-2-67:1995+AMD1:2019 CSV (Consolidated version) Environmental testing – Part 2-67: Tests – Test Cy: Damp heat, steady state, accelerated test primarily intended for components

Humidity/corrosion testing – alternative

IEC 60068-2-68:1994 – Environmental testing – Part 2-68: Tests – Test L: Dust and sand

Dust ingress test

IEC 60068-2-70:1995 – Environmental testing – Part 2-70: Tests – Test Xb: Abrasion of markings and letterings caused by rubbing of fingers and hands

Security of markings subject to abrasion by fingers during use

IEC 60068-2-78:2012 RLV (Redline version) Environmental testing – Part 2-78: Tests – Test Cab: Damp heat, steady state

Humidity/corrosion testing – alternative

IEC 60130-10:1971 – Part 10: Connectors for coupling and external low-voltage power supply to portable entertainment equipment

The nearest the IEC has to a barrel connector standard – but it isn't the barrel connector we're familiar with

IEC 60320-1:2015 – APPLIANCE COUPLERS FOR HOUSEHOLD AND SIMILAR GENERAL PURPOSES – Part 1: General requirements

Although referring to mains-powered equipment, this standard defines the terms to be used when describing the interconnection between an electricity source and a load.

IEC 60320-3:2014 – APPLIANCE COUPLERS FOR HOUSEHOLD AND SIMILAR GENERAL PURPOSES – Part 3: Standard sheets and gauges

An example of how connector dimension tolerances should be specified. An equivalent document for barrel connectors either needs to be found, or written.

IEC 60335-1:2020 CMV (Commented version) Household and similar electrical appliances – Safety – Part 1: General requirements

This is where the mandatory electrical equipment ratings plate is defined.

IEC 60512 (all parts) – Connectors for

These parts list the parameters that should be

electrical and electronic equipment - Tests and measurements

defined when writing a test procedure for a connector pair. Only some of these tests will be relevant.

IEC 60529:1989+AMD1:1999+AMD2:2013 CSV (Consolidated version) Degrees of protection provided by enclosures (IP Code)

Protection against ingress of water or dust

IEC 60603-11:1992 - Connectors for frequencies below 3 MHz for use with printed boards - Part 11: Detail specification for concentric connectors (dimensions for free connectors and fixed connectors)

This may relate to printed-circuit mounted barrel connector sockets (I don't have visibility of it)

IEC 60950-22:2016 RLV (Redline version) Information technology equipment - Safety - Part 22: Equipment to be installed outdoors

Useful test for all aspects of electronic equipment in uncontrolled environments

ISO 16750-2:2012(E) - Road vehicles - Environmental conditions and testing for electrical and electronic equipment - Part 2: Electrical loads

Detailed instructions for testing 12V equipment for automotive environments

**Note:** *Buying all these standards will be very expensive, and large parts will be irrelevant. In future, we may précis the relevant tests from these standards, and incorporate them in this document.*

## **10. Appendix III – Testing of Connectors**

### **10.1. Reference Connectors**

#### 10.1.1. Definition

Reference connectors are plugs and sockets that have been found to work well with the majority of sockets and plugs found in the global marketplace. The manufacturer's chosen connector will be tested by mating with the appropriate reference connector, in order for its performance to be assessed.

#### 10.1.2. Use

A reference plug is used in testing with candidate socket products, to determine whether they will work satisfactorily together. This ensures that connectors of too low quality are not used, because they would cause reliability problems in the field. Similarly, a reference socket is used to test possible plugs.

Unfortunately, product testing degrades both the connector under test and the connector to which it is mated, so a supply of reference connectors is needed.

#### 10.1.3. Selection

It is essential that the chosen reference connectors are tested with a wide variety of the connectors that are going to be found in practice. Initially, it is proposed that each of the Connect Affiliates is asked to provide some samples for testing.

In terms of physical dimensions, the reference connectors should be in the middle of the range. Plating and contact pressure should be typical of those found in practice.

The reference connectors must come from a manufacturer who has tight control over his tolerances (certainly tighter than many of the products being tested). The product line must be stable, such that a consistent supply of reference connectors is available over a long period of time.

The selection process must involve obtaining a wide selection of plugs and sockets from the field (perhaps on products which might be faulty) and subjecting them to extensive testing to determine which plug works with the majority of sockets, and which socket with the majority of plugs.

Having chosen a possible reference connector, a quantity should be procured from the manufacturer, and the manufacturing tolerances established, to determine whether the connectors are repeatable. If the tolerances are found to be wide, a different connector will have to be found.

### **10.2. Testing**

It is intended that a connector testing service will be established, to test connectors that Connect Affiliates are hoping to use on their products. A list of connectors that have already been tested and found acceptable may be published.

### 10.2.1. Testing Objectives

The procedures defined here are not methods for evaluating a connector against a standard. (As far as we can tell, an internationally recognised standard for LVDC barrel connectors does not exist.) Rather the tests defined here are designed to answer one simple question, “If I adopt this connector for my product, am I likely to experience problems in the field?”

All mass-produced items have physical dimensions that vary slightly, typically with a Gaussian distribution. Low-cost items typically show wider variation than more expensive ones. The quality of the materials may also vary. Using too poor a connector will cause problems later, so techniques are needed to evaluate possible connectors in the lab and avoid this.

There are well-established procedures for testing the electrical and mechanical properties of connectors – but most electrical and mechanical properties cannot be tested meaningfully on a single connector – it is only possible to test the characteristics of a mated pair. Therefore, when testing a socket in isolation, suitable plugs must be found that are expected to be plugged into it – and equally, suitable sockets found for testing every plug provided with an appliance.

### 10.2.2. Testing of Sockets

You should test your socket with the reference plug, as this is a realistic simulation of what will happen in practice.

A sample of the chosen reference plug should be connected to a 200g weight and a load resistor (if necessary water or air-cooled), a rheostat or an electronic load. A voltage monitor should also be connected. The same equipment may be used as defined below in §6.1.1 for testing SHS voltage.

(A supply of reference connectors is needed because it is likely that the mating reference connector which is not under test will degrade during a run, along with the mating connector that is being tested.)

### 10.2.3. Testing of Plug Leads

A sample of the reference socket must be rigidly mounted onto a printed circuit board that may be held rigidly in the test rig. The socket should be powered for the test, so that the test can be conducted under current. A standard 12V lab power supply able to deliver the rated current of the port will suffice.

The plug lead under test should be connected to a 200g weight and a load resistor (if necessary water or air-cooled), a rheostat or an electronic load. A voltage monitor should



also be connected. The same equipment may be used as defined below in §6.1.1 for testing SHS voltage.

#### 10.2.4. What to test for

There is an almost limitless number of different tests that may be applied to a mated connector pair. It makes sense to concentrate on those tests that are most likely to anticipate failures in the field. Beyond gross errors (the wrong type of connector, overmoulding too large to go into a recessed socket, etc), the issues with barrel connectors that are known to cause issues are:

- Excessive or insufficient insertion and withdrawal force
- Plug barrel too short or socket hole not deep enough
- Intermittent contact or excessive contact resistance (causing heating and voltage loss when carrying current) when subjected under load to:
  - Humidity and corrosion
  - Repeated insertion/withdrawal
  - Tension on the lead at an angle
- Unreliable solder joints to the printed circuit (SHS sockets only)
- Weak cable entry to the plug (appliances only)

The various sections of IEC 60512 describe the parameters that must be defined for tests against these weaknesses, but do not suggest values for those parameters. It is therefore for us to specify reasonable values that will show problems up, but not cause the tests to be too lengthy or tedious to perform or be so extreme as to cause problems that will never occur in practice.

##### 10.2.4.1. Connector Test Rig

Subjecting the connectors to all the hazards listed above simultaneously is likely to show up poor products very quickly. It is therefore suggested that a test rig be constructed, to test candidate products, and quickly identify those products that if adopted would cause problems later.

Such a test rig would have:

- For testing SHS sockets, a range of representative power leads similar to those likely to be found on appliances, connected to a load drawing the maximum current supported by the SHS, and connected to a voltage monitor
- For testing appliance leads, a power supply with a representative range of sockets, and able to supply the maximum rated current of the appliance (this could be a modified SHS)
- A gimbal mount for the SHS or power supply to assess cable entry at various angles, preferably motorised.

A sketch of a possible test rig arrangement is shown below:

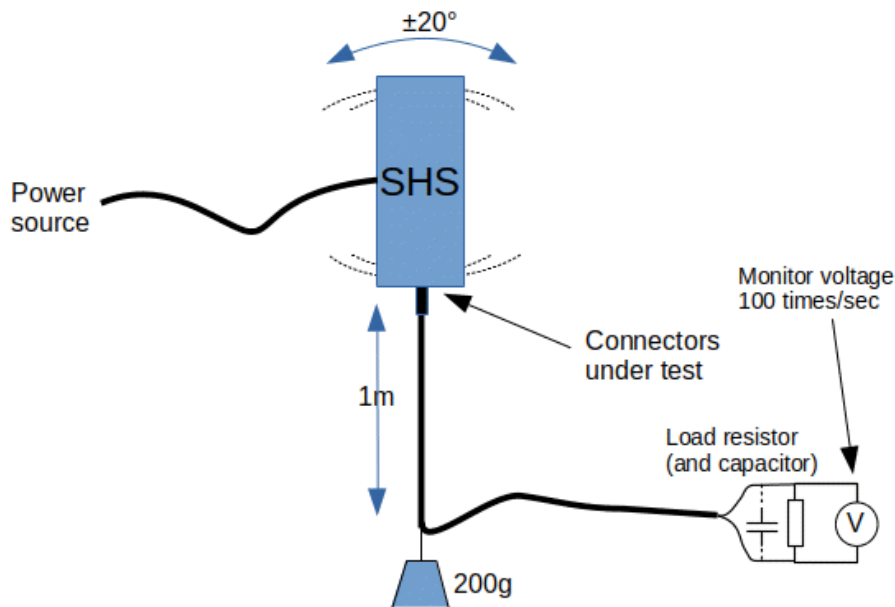

It is suggested that the gimbal mount be wobbled sinusoidally  $\pm 20^\circ$  at 0.5Hz fifty times each in every direction (0/180°, 45/225°, 90/270°, 135/315°). With 200g load on the lead, the connectors should not come apart. The voltage across the load should not vary by more than 100mV at any point during the test.

A static test showing immediate disconnection with a 900g load along the axis of the connectors will suffice to demonstrate that the withdrawal force is not excessive.

A separate test rig is likely to be required for testing repeated insertion and withdrawal of connectors under load. A value of 500 insertions/withdrawals under load is suggested. In this case, the load should have an electrolytic capacitor across it of approximately (rated amps x 50 $\mu$ F), and the speed of operation should be no greater than 2Hz.

#### 10.2.4.2. Is all this concern with testing connectors really necessary?

I took a straw poll of all the nominally 5.5mm barrel connectors (5521 and 5525) in my junk boxes. The following minimum diameters were found:

5.39mm	2
5.40mm	1
5.41mm	2
5.42mm	4
5.43mm	1
5.44mm	1
5.45mm	3

5.48mm	1
5.50mm	1

(I say 'minimum diameter' as several of them were far from round – the most oval was one that was minimum diameter 5.39mm, maximum diameter 5.45mm!)

It was noteworthy that the barrels were also of many different lengths, from 9.80mm to 12.46mm.

These dimensions are relatively easy to measure. It is recommended that Connect Affiliates acquire a digital micrometer with a resolution of 0.01mm or better, to see these variations for themselves.

It is difficult to measure the inner hole in the plug accurately with a micrometer. For this it is recommended that Connect Affiliates acquire a set of hole gauges 1mm–6mm in 0.1mm steps, in order to verify that connector dimensions are indeed as specified. A suitable hole gauge set would be RS [785-7881](#). Alternatively, a source of twist drills that may be used as hole gauges is the Dormer part number [A190202](#).

However, this only gives a measurement to the nearest 0.1mm. A better solution is a set of hole gauges (eg <https://uk.rs-online.com/web/p/bore-gauges/8771804>), but these aren't cheap.

The barrel jack sockets are altogether more challenging to measure accurately. This is for further study, but for now the best solution seems to be to select the largest and smallest of the plugs, and confirm that both of these mate reliably using the test rig above.

(ends)